

DESCRIPTION

The 78P2351R is Teridian's second generation Line Interface Unit (LIU) for 155 Mbit/s electrical SDH interfaces (STM1e). The device is a single chip solution that includes an integrated Clock & Data Recovery in both the transmit and receive paths for easy, cost efficient NRZ to CMI conversion.

The device interfaces to 75Ω coaxial cable through wideband transformers and can handle over 12.7dB of cable loss. By eliminating the needs for synchronous clocks, the small 78P2351R (7x7mm MLF package) is ideal for new STM1e (ES1) Small Form-factor Pluggable (SFP) transceiver modules.

APPLICATIONS

- STM1e SFP modules
- SDH/ATM Line Cards
- Add Drop Multiplexers (ADMs)
- PDH/SDH Test Equipment
- Digital Microwave Radios
- Multi-Service Switches

FEATURES

- ITU-T G.703 compliant, adjustable cable driver for 155.52 Mbps CMI-coded coax transmission
- Integrated adaptive CMI equalizer and CDR in receive path handles over 12.7dB of cable loss
- LVPECL-compatible system interface with integrated CDR in transmit path for flexible NRZ to CMI conversion
- Configurable via HW control pins or 4-wire serial port interface
- Compliant with ANSI T1.105.03-1994; ITU-T G.813, G.825, G.958; and Telcordia GR-253-CORE for jitter performance
- Receive Loss of Signal (Rx LOS) detection
- Receive Monitor Mode handles up to 20dB of flat loss (at max 6dB cable loss)
- Optional fixed backplane equalizer compensates for up to 1.5m of trace
- Operates from a single 3.3V supply
- Available in a small 7x7mm 56-pin QFN package
- Industrial Temperature: -40°C to +85°C

BLOCK DIAGRAM

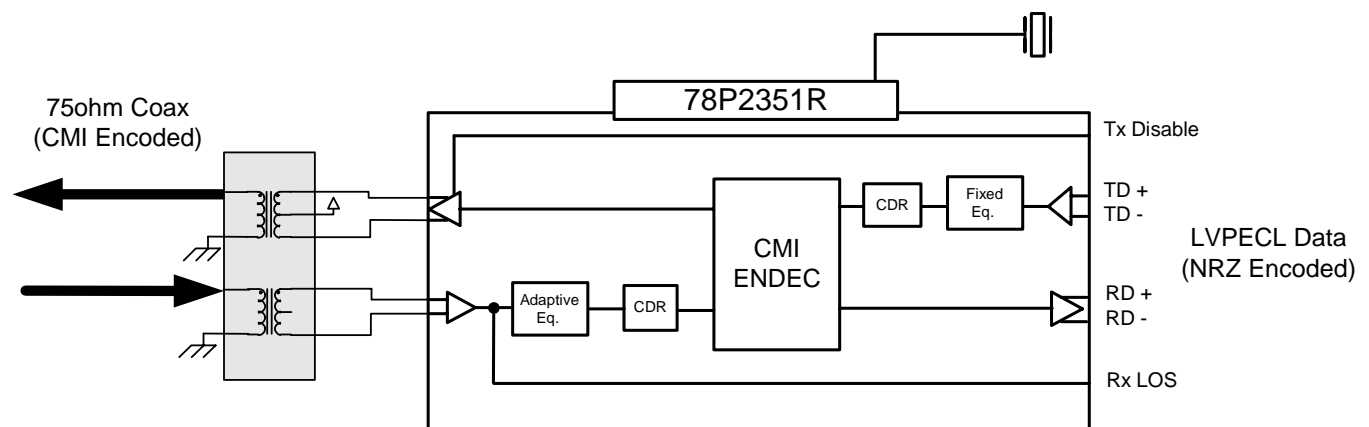

TABLE OF CONTENTS	2
FUNCTIONAL DESCRIPTION	4
REFERENCE CLOCK	4
RECEIVER OPERATION	4
<i>Receiver Monitor Mode</i>	4
<i>Receive Loss of Signal</i>	4
TRANSMITTER OPERATION	5
<i>Plesiochronous Mode</i>	5
<i>Synchronous Mode</i>	5
<i>Clock Synthesizer</i>	5
<i>Pulse Amplitude Adjustment</i>	6
<i>Transmit Backplane Equalizer</i>	6
POWER-DOWN FUNCTION	6
LOOPBACK MODES	6
POWER-ON RESET	7
SERIAL CONTROL INTERFACE	7
REGISTER DESCRIPTION	8
REGISTER ADDRESSING	8
REGISTER TABLE	8
LEGEND	9
GLOBAL REGISTERS	9
ADDRESS 0-0: MASTER CONTROL REGISTER	9
PORT-SPECIFIC REGISTERS	10
ADDRESS 1-0: MODE CONTROL REGISTER	10
ADDRESS 1-1: SIGNAL CONTROL REGISTER	11
ADDRESS 1-2: ADVANCED TX CONTROL REGISTER 1	11
ADDRESS 1-3: ADVANCED TX CONTROL REGISTER 0	12
ADDRESS 1-4: RESERVED	12
ADDRESS 1-5: STATUS MONITOR REGISTER	12
ADDRESS 1-6, 1-7: RESERVED	13
PIN DESCRIPTION	14
LEGEND	14
TRANSMITTER PINS	14
RECEIVER PINS	14
REFERENCE AND STATUS PINS	14
CONTROL PINS	15
SERIAL-PORT PINS	16
POWER AND GROUND PINS	16

TABLE OF CONTENTS (continued)

ELECTRICAL SPECIFICATIONS	17
ABSOLUTE MAXIMUM RATINGS	17
RECOMMENDED OPERATING CONDITIONS	17
DC CHARACTERISTICS	17
ANALOG PINS CHARACTERISTICS	18
DIGITAL I/O CHARACTERISTICS	18
<u>Pins of type CI, CID</u>	18
<u>Pins of type CIT</u>	18
<u>Pins of type CIS</u>	18
<u>Pins of type COZ</u>	18
<u>Pins of type PO</u>	19
<u>Pins of type PI</u>	19
<u>Pins of type OD</u>	19
REFERENCE CLOCK CHARACTERISTICS	19
SERIAL-PORT TIMING CHARACTERISTICS	20
TRANSMITTER SPECIFICATIONS FOR CMI INTERFACE	21
TRANSMITTER OUTPUT JITTER	24
RECEIVER SPECIFICATIONS FOR CMI INTERFACE (Transformer-coupled)	25
RECEIVER JITTER TOLERANCE	26
RECEIVER JITTER TRANSFER FUNCTION	27
LOSS OF SIGNAL CONDITIONS	28
APPLICATION INFORMATION	28
EXTERNAL COMPONENTS	28
TRANSFORMER SPECIFICATIONS	28
THERMAL INFORMATION	28
MECHANICAL SPECIFICATIONS	29
PACKAGE INFORMATION	30
ORDERING INFORMATION	30
Revision History	31

FUNCTIONAL DESCRIPTION

The 78P2351R contains all the necessary transmit and receive circuitry for connection between 155.52Mbit/s NRZ data sources (STS-3/STM-1) and CMI encoded electrical interfaces (ES1/STM-1e). The 78P2351R system interface mimics a 3.3V optical transceiver module and only requires a reference clock and wideband transformer to complete the electrical interface. The chip can be controlled via control pins or serial port register settings.

In hardware mode (pin control) the SPSL pin must be low. Additionally, the following unused pins must be set accordingly:

- SDO pin must be tied low
- SDI pin must be tied low
- SEN pin must be tied high

In software mode (SPSL pin high), control pins set register defaults upon power-up or reset. The 78P2351R can then be configured via the 4-wire serial control interface. See Pin Descriptions section for more information.

REFERENCE CLOCK

The 78P2351R requires a reference clock supplied to the CKREFP/N pins. For reference frequencies of 19.44MHz or 77.76MHz, the device accepts a single ended CMOS level input at CKREFP (with CKREFN pin tied to ground). For reference frequency of 155.52MHz, the device accepts a differential LVPECL clock input at CKREFP/N. The frequency of this reference input is selected by either the CKSL control pin or register bit as follows:

CKSL pin	CKSL[1:0] bits	Reference Frequency
Low	0 0	19.44MHz
Float	1 0	77.76MHz
High	1 1	155.52MHz

RECEIVER OPERATION

The receiver accepts an ITU-T G.703 compliant CMI encoded signal at 155.52Mbit/s from the RXP/N inputs. When properly terminated and transformer-coupled to the line, the receiver can handle over 12.7dB of cable loss. The receiver's jitter tolerance exceeds all relevant standards even with 12.7dB worth of cable attenuation and inter-symbol interference (ISI). See Receiver Jitter Tolerance section for more info.

The recovered CMI signal first enters an AGC and an adaptive equalizer designed to overcome inter-symbol interference caused by long cable lengths. The variable gain differential amplifier automatically controls the gain to maintain a constant voltage level output regardless of the input voltage level.

The outputs of the data comparators are connected to the clock recovery circuits. The clock recovery system employs a Delay Locked Loop (DLL), which utilizes a line-rate reference frequency derived from the clock applied to the CKREFP/N pins. After the clock and data have been recovered, the data is decoded to binary by the CMI decoder. The SODP/N pins output the recovered NRZ data at LVPECL levels.

Receiver Monitor Mode

The SCK_MON pin or MON register bit puts the receiver in monitor mode and adds approximately 20dB of **flat gain** to the receive signal before equalization. Rx Monitor Mode can handle 20dB of flat loss typical of monitoring points with up to 6dB (typical 225ft) of cable loss. Note that Loss of Signal detection is disabled during Rx Monitor Mode.

Receive Loss of Signal Detect

The 78P2351R includes a Loss of Signal (LOS) detector. When the peak value of the received signal is less than approximately 19dB below nominal for approximately 110 UI, Receive Loss of Signal is asserted. The Rx LOS signal is cleared when the received signal is greater than approximately 18dB below nominal for 110 UI.

During Rx LOS conditions, the receive clock will remain on the last phase tap of the Rx DLL outputting a stable clock while the receive data outputs are squelched and held at logic '0'.

Note: Rx Loss of Signal detection is disabled during Local Loopback and Receive Monitor Modes.

TRANSMITTER OPERATION

The transmitter section generates an adjustable ITU-T G.703 compliant analog signal for transmission through a wideband transformer onto 75Ω coaxial cable. Differential NRZ data is input to the 78P2351R on the SIDP/N pins at LVPECL levels and passed to a low jitter clock and data recovery circuit. An optional clock decoupling FIFO is provided to decouple the on chip and off chip clocks. The NRZ data is encoded using CMI line coding to ensure an adequate number of transitions.

Each of the transmit timing modes can be configured in HW mode or SW mode as shown in the table below.

Tx Mode	HW Control	SW Control
	CKMODE	SMOD[1:0]
Reserved	Low	0 0
Synchronous (FIFO enabled)	Floating	1 0
Plesiochronous	High	0 1
Loop-timing	n/a	1 1

Plesiochronous Mode

Plesiochronous mode represents a common condition where a synchronous reference clock is not available. In this mode, the 78P2351R will recover the transmit clock from the plesiochronous data and bypass the internal FIFO and re-timing block. This mode is commonly used for mezzanine cards, modules, and any application where the reference clock can't always be synchronous to the transmit source clock/data

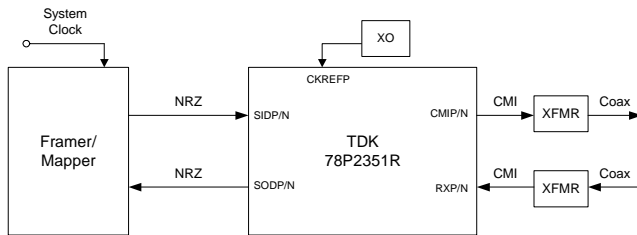

Figure 1: Plesiochronous Mode

Synchronous Mode

When the NRZ transmit data is source synchronous with the reference clock applied at CKREFP/N as shown in Figure 2, the 78P2351R can be optionally used in synchronous mode or re-timing mode. In this mode, the 78P2351R will recover the clock from the NRZ data input and re-time the data in an integrated +/- 4-bit FIFO.

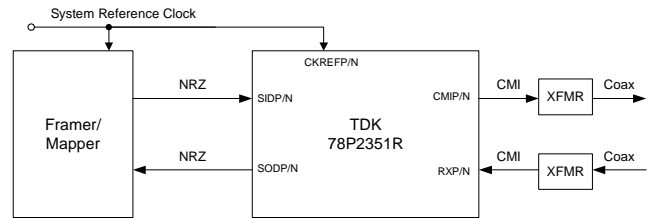

Figure 2: Synchronous

Since the reference clock and transmit clock/data go through different delay paths, it is inevitable that the phase relationship between the two clocks can vary in a bounded manner due to the fact that the absolute delays in the two paths can vary over time. The transmit FIFO allows long-term clock phase drift between the Tx clock and system reference clock, not exceeding +/- 25.6ns, to be handled without transmit error. If the clock wander exceeds the specified limits, the FIFO will over or under flow, and the FERR register signal will be asserted. This signal can be used to trigger an interrupt. This interrupt event is automatically cleared when a FIFO Reset (FRST) pulse is applied, and the FIFO is re-centered.

Notes:

- 1) External remote loopbacks (i.e. loopback within framer) are not possible in synchronous operation (FIFO enabled) unless the data is re-justified to be synchronous to the system reference clock or the 78P2351R is configured for loop-timing operation.
- 2) During IC power-up or transmit power-up, the clocks going to the FIFO may not be stable and cause the FIFO to overflow or underflow. As such, the FIFO should be manually reset using FRST anytime the transmitter is powered-up.

Clock Synthesizer

The transmit clock synthesizer is a low-jitter PLL that generates a 311.04 MHz clock for the CMI encoder. A synthesized 155.52 MHz reference clock is also used in both the receive and transmit sides for clock and data recovery.

Pulse Amplitude Adjustment

Contact TDK applications for information on user programmable registers with up to 200mV of programmable transmit gain.

Transmit Backplane Equalizer

An optional fixed LVPECL equalizer is integrated in the transmit path for architectures that use LIUs on active interface cards. The fixed equalizer can compensate for up to 1.5m of trace and can be enabled by the TXOUT1 pin or TXEQ bit as follows:

TXOUT1 pin	TXEQ bit	Tx Equalizer
Low	1	Enabled
Float	0	Disabled

POWER-DOWN FUNCTION

Power-down control is provided to allow the 78P2351R to be shut off. Transmit and receive power-down can be set independently through SW control. Global power-down is achieved by powering down both the transmitter and receiver.

Note: the 4-wire serial port interface and configuration registers are not affected by power-down.

The transmitter can also be powered down using the TXPD control pin. The CMI outputs are tri-stated during transmit power-down for redundancy applications. The TXPD pin is active in both hardware and software modes.

LOOPBACK MODES

In SW mode, LLBK and RLBK bits in the Signal Control register are provided to activate the local and remote analog loopback modes respectively.

In HW mode, the LPBK pin can be used to activate local and remote analog loopback paths as shown in the table below.

LPBK pin	Loopback Mode
Low	Normal operation
Float	<u>Remote (analog) Loopback:</u> Recovered receive clock and data looped back directly to the transmit driver. The CMI decoder and most of transmit path is bypassed (including the redundant Tx monitor output)
High	<u>Local (analog) Loopback:</u> Transmit clock and data looped back to receiver at the analog media interface.

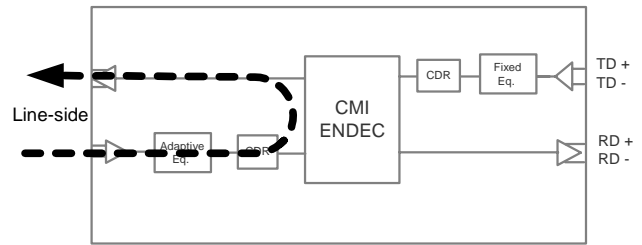

Figure 3: Remote (analog) Loopback

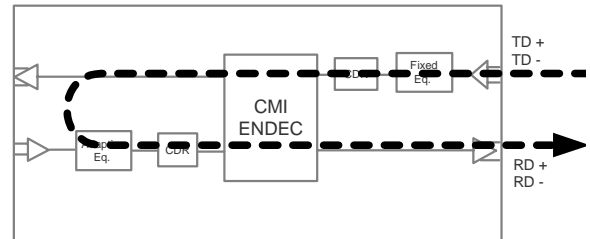

Figure 4: Local (analog) Loopback

In SW mode only, a Full Remote (digital) Loopback bit FLBK is also available in the Advanced Tx Control register. This loopback exercises the entire Rx and Tx paths of the 78P2351 including the Tx clock recovery unit. As such, the user must enable either Plesiochronous or Loop-timing transmit modes to utilize the Full Remote (digital) Loopback.

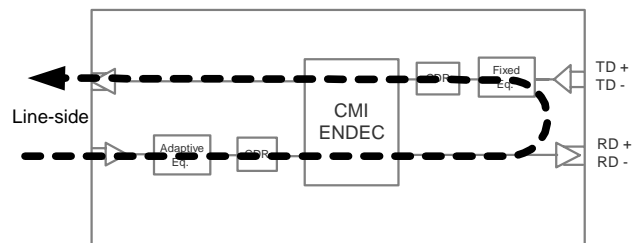

Figure 5: Remote (Digital) Loopback

INTERNAL POWER-ON RESET

Power-On Reset (POR) function is provided on chip. Roughly 50 μ s after V_{cc} reaches 2.4V at power up, a reset pulse is internally generated. This resets all registers to their default values as well as all state machines within the transceiver to known initial values. The reset signal is also brought out to the PORB pin. The PORB pin is a special function analog pin that allows for the following:

- Override the internal POR signal by driving in an external active low reset signal;
- Use the internally generated POR signal to trigger other resets;
- Add external capacitor to slow down the release of power-on reset (approximately 8 μ s per nF added).

NOTE: Do not pull-up the PORB pin to V_{cc} or drive this pin high during power-up. This will prevent the internal reset generator from resetting the entire chip and may result in errors.

SERIAL CONTROL INTERFACE

The serial port controlled register allows a generic controller to interface with the 78P2351R. It is used for mode settings, diagnostics and test, retrieval of status and performance information, and for on-chip fuse trimming during production test. The SPSL pin must be high in order to use the serial port.

The serial interface consists of 4 pins:

- Serial Port Enable (SEN),
- Serial Clock (SCK_MON),
- Serial Data In (SDI),
- Serial Data Out (SDO).

The SEN pin initiates the read and write operations. It can also be used to select a particular device allowing SCK_MON, SDI and SDO to be bussed together.

SCK_MON is the clock input that times the data on SDI and SDO. Data on SDI is latched in on the rising-edge of SCK_MON, and data on SDO is clocked out using the falling edge of SCK_MON.

SDI is used to insert mode, address, and register data into the chip. Address and Data information are input least significant bit (LSB) first. The mode and address bit assignment and register table are shown in the following section.

SDO is a tristate capable output. It is used to output register data during a read operation. SDO output is normally high impedance, and is enabled only during the duration when register data is being clocked out. Read data is clocked out least significant bit (LSB) first.

If SDI coming out of the micro-controller chip is also tristate capable, SDI and SDO can be connected together to simplify connections.

The maximum clock frequency for register access is 20MHz.

REGISTER DESCRIPTION

REGISTER ADDRESSING

Address Bits	Bit 7	Bit 6	Bit 5	Bit 4	Bit 3	Bit 2	Bit 1	Bit 0
	Port Address				Sub-Address			Read/ Write
Assignment	PA[3]	PA[2]	PA[1]	PA[0]	SA[2]	SA[1]	SA[0]	R/W*

REGISTER TABLE

a) PA[3:0] = 0 : Global Registers

Sub Addr	Reg. Name	Description	Bit 7	Bit 6	Bit 5	Bit 4	Bit 3	Bit 2	Bit 1	Bit 0
0	MSCR (R/W)	Master Control	-- <0>	-- <0>	-- <0>	CKSL[1] <X>	CKSL[0] <X>	-- <X>	-- <X>	SRST <0>
1	-- (R/W)	Reserved	-- <0>	-- <0>	-- <1>	-- <0>	-- <0>	-- <0>	-- <1>	-- <1>
2	-- (R/W)	Reserved	-- <X>	-- <X>	-- <X>	-- <X>	-- <X>	-- <X>	-- <X>	-- <0>

b) PA[3:0] = 1 : Port-Specific Registers

Sub Addr	Reg. Name	Description	Bit 7	Bit 6	Bit 5	Bit 4	Bit 3	Bit 2	Bit 1	Bit 0
0	MDCR (R/W)	Mode Control	PDTX <0>	PDRX <0>	-- <0>	SMOD[1] <X>	SMOD[0] <X>	MON <0>	-- <0>	-- <1>
1	SGCR (R/W)	Signal Control	TCMIINV <0>	RCMIINV <0>	LOSOR <0>	RLBK <0>	LLBK <0>	-- <0>	-- <0>	FRST <0>
2	ACR1 (R/W)	Advanced Tx Control 1	-- <0>	-- <0>	-- <0>	-- <0>	-- <0>	-- <0>	TPK <0>	TXEQ <0>
3	ACR0 (R/W)	Advanced Tx Control 0	-- <1>	-- <0>	-- <1>	-- <0>	-- <1>	BST[1] <0>	BST[0] <0>	FLBK <0>
4	-- (R/W)	Reserved	-- <1>	-- <X>	-- <X>	-- <0>	-- <0>	-- <0>	-- <0>	-- <0>
5	STAT (R/C)	Status Monitor	-- <X>	-- <X>	-- <X>	RXLOS <X>	-- <X>	-- <X>	TXLOS <X>	FERR <X>
6-7	--	Reserved	--	--	--	--	--	--	--	--

REGISTER DESCRIPTION (continued)

LEGEND

TYPE	DESCRIPTION	TYPE	DESCRIPTION
R/O	Read only	R/W	Read or Write
R/C	Read and Clear		

GLOBAL REGISTERS

ADDRESS 0-0: MASTER CONTROL REGISTER

BIT	NAME	TYPE	DFLT VALUE	DESCRIPTION
7:5	--	R/W	0X0	Reserved.
4:3	CKSL [1:0]	R/W	X	Reference Clock Frequency Select: Selects the reference clock frequency input at CKREFP/N pins. 11: 155.52 MHz (differential LVPECL input) 10: 77.76 MHz (single-ended CMOS input) – Tie CKREFN to ground. 00: 19.44 MHz (single-ended CMOS input) – Tie CKREFN to ground. Note: Default values depend on the CKSL pin setting upon reset or power up.
2:1	--	R/W	X0	Reserved.
0	SRST	R/W	0	Register Soft-Reset: When this bit is set, all registers are reset to their default values. This register bit is self-clearing.

ADDRESS 0-1: RESERVED

BIT	NAME	TYPE	DFLT VALUE	DESCRIPTION
7:0	--	R/W	00100X11	Reserved.

ADDRESS 0-2: RESERVED

BIT	NAME	TYPE	DFLT VALUE	DESCRIPTION
7:0	--	R/W	XXXXXXXX0	Reserved.

REGISTER DESCRIPTION (continued)

PORT-SPECIFIC REGISTERS

For PA[3:0] = 1 only. Accessing a register with port address greater than 1 constitutes an invalid command, and the read/write operation will be ignored.

ADDRESS 1-0: MODE CONTROL REGISTER

BIT	NAME	TYPE	DFLT VALUE	DESCRIPTION
7	PDTX	R/W	0	Transmitter Power-Down: 0 : Normal Operation 1 : Power-Down. CMI Transmit output is tri-stated.
6	PDRX	R/W	0	Receiver Power-Down: 0 : Normal Operation 1 : Power-Down
5	--	R/W	0	Reserved.
4	SMOD[1]	R/W	X	Serial Mode Interface Selection: <u>SMOD[1] SMOD[0]</u> 0 0 Reserved 1 0 <u>Synchronous data</u> is passed through the CDR and then through the FIFO. 0 1 <u>Plesiochronous data</u> is passed through the CDR to recover a clock, but the FIFO is bypassed because the data is not synchronous with the reference clock. 1 1 <u>Loop Timing Mode Enable:</u> The recovered receive clock is used as the reference for the transmit DLL and FIFO. Note: Default values depend on the CKMODE pin setting upon reset or power up.
3	SMOD[0]	R/W	X	
2	MON	R/W	0	Receive Monitor Mode Enable: 0: Normal Operation 1: Adds 20dB of flat gain to the receive signal before equalization.
1:0	--	R/W	01	Reserved.

REGISTER DESCRIPTION (continued)

ADDRESS 1-1: SIGNAL CONTROL REGISTER

BIT	NAME	TYPE	DFLT VALUE	DESCRIPTION												
7	TCMIINV	R/W	0	Transmit CMI Inversion: This bit will flip the polarity of the transmit CMI data outputs at CMIP/N. For debug use only. 0: Normal 1: Invert												
6	RCMIINV	R/W	0	Receive CMI Inversion: This bit will flip the polarity of the receive CMI data inputs at RXP/N. For debug use only. 0: Normal 1: Invert												
5	LOSOR	R/W	0	Receive Loss of Signal Override/Disable: When set, the LOS signal will always remain low. 0: Normal 1: Forces LOS output to be low and resets counter												
4	RLBK	R/W	0	Analog Loopback Selection: <table border="0"> <tr> <td><u>RLBK</u></td> <td><u>LLBK</u></td> <td></td> </tr> <tr> <td>0</td> <td>0</td> <td>Normal operation</td> </tr> <tr> <td>1</td> <td>0</td> <td><u>Remote Loopback Enable:</u> Recovered receive data is looped back to the transmit driver for retransmission.</td> </tr> <tr> <td>0</td> <td>1</td> <td><u>Local Loopback Enable:</u> The transmit data is looped back and used as the input to the receiver.</td> </tr> </table>	<u>RLBK</u>	<u>LLBK</u>		0	0	Normal operation	1	0	<u>Remote Loopback Enable:</u> Recovered receive data is looped back to the transmit driver for retransmission.	0	1	<u>Local Loopback Enable:</u> The transmit data is looped back and used as the input to the receiver.
<u>RLBK</u>	<u>LLBK</u>															
0	0	Normal operation														
1	0	<u>Remote Loopback Enable:</u> Recovered receive data is looped back to the transmit driver for retransmission.														
0	1	<u>Local Loopback Enable:</u> The transmit data is looped back and used as the input to the receiver.														
3	LLBK	R/W	0													
2:1	--	R/W	00	Reserved.												
0	FRST	R/W	0	FIFO Reset: 0: Normal operation 1: Reset FIFO pointers to default locations. This reset should be initiated anytime the transmitter or IC powers up to ensure the FIFO is centered after internal VCO clocks and external transmit clocks are stable. NOTE: FIFO reset not required for Plesiochronous Mode												

ADDRESS 1-2: ADVANCED TRANSMIT CONTROL REGISTER 1

BIT	NAME	TYPE	DFLT VALUE	DESCRIPTION
7:1	--	R/W	000000 0	Reserved.
0	TXEQ	R/W	0	Transmit Fixed Equalizer Enable: When enabled, compensates for between 0.75m and 1.5m of FR4 trace to the LVPECL data inputs SIDP/N 0: Normal Operation 1: Enable equalizer

REGISTER DESCRIPTION (continued)

ADDRESS 1-3: ADVANCED TRANSMIT CONTROL REGISTER 0

BIT	NAME	TYPE	DFLT VALUE	DESCRIPTION
7:3	--	R/W	10101	Reserved.
2:1	BST[1:0]	R/W	00	Transmit Driver Amplitude Boost: Adds 5% or 10% of boost to the CMI output. 00 : Normal amplitude 01 : 5% boost 10 : Reserved 11 : 10% boost
0	FLBK	R/W	0	Full Remote (digital) Loopback Enable: When enabled the recovered receive data is decoded and looped back to the transmit clock recovery unit exercising the entire receive and transmit paths. NOTE: Must be used in conjunction with Plesiochronous Mode or Loop-Timing Mode.

ADDRESS 1-4: RESERVED

BIT	NAME	TYPE	DFLT VALUE	DESCRIPTION
7:0	--	R/W	1XX00000	Reserved.

ADDRESS 1-5: STATUS MONITOR REGISTER

BIT	NAME	TYPE	DFLT VALUE	DESCRIPTION
7:5	--	R/C	XXX	Reserved.
4	RXLOS	R/C	X	Receive Loss of Signal Indication: 0: Normal operation 1: Loss of signal condition detected at CMI inputs
3:2	--	R/C	X	Reserved.
1	TXLOS	R/C	X	Transmit Loss of Signal Indication: 0: Valid transmit input signal detected at SIDP/N 1: No valid signal detected at SIDP/N
0	FERR	R/C	X	Transmit FIFO Error Indication: This bit is set whenever the internal FERR signal is asserted, indicating that the FIFO is operating at its depth limit. It is reset to 0 when the FRST bit is asserted. 0: Normal operation 1: Transmit FIFO phase error

ADDRESS 1-6: TRANSMIT GAIN REGISTER

BIT	NAME	TYPE	DFLT VALUE	DESCRIPTION
7:0	RSVD	R/O	0	Reserved for pulse amplitude programmability. Contact Teridian applications support for more information.

ADDRESS 1-7: RESERVED

BIT	NAME	TYPE	DFLT VALUE	DESCRIPTION
7:0	RSVD	R/O	0	Reserved for test.

PIN DESCRIPTION

LEGEND

TYPE	DESCRIPTION	TYPE	DESCRIPTION
A	Analog Pin	PO	LVPECL-Compatible Differential Output
CIT	3-State CMOS Digital Input	OD	Open-drain Output
CI	CMOS Digital Input	PI	LVPECL-Compatible Differential Input
CID	CMOS Digital Input w/ Pull-down	S	Supply
CIS	CMOS Schmitt Trigger Input	G	Ground
COZ	CMOS Tristate Digital Output		

TRANSMITTER PINS

NAME	PIN	TYPE	DESCRIPTION
SIDP SIDN	4 5	PI	Transmit Serial Data Input: Differential NRZ data input. See <i>Transmitter Operation</i> section for more info on different timing modes.
CMIP CMIN	53 54	A	Transmit Serial CMI Data Output: A CMI encoded data signal conforming to the relevant ITU-T G.703 pulse templates when properly terminated and transformer coupled to 75ohm cable. Notes: 1) Pins are tri-stated during transmit power-down. 2) Pins are active, but undefined during reset.

RECEIVER PINS

NAME	PIN	TYPE	DESCRIPTION
SODP SODN	13 14	PO	Receive Serial NRZ Data Output: Recovered serial data decoded into NRZ format and output at LVPECL levels. Notes: 1) Outputs are squelched during LOS and held low. 2) Pins are active, but undefined during reset.
RXP RXN	50 51	A	Receive Serial CMI Input: Receive inputs that should be differentially terminated and transformer coupled to the coaxial cable.

REFERENCE AND STATUS PINS

NAME	PIN	TYPE	DESCRIPTION
CKREFP CKREFN	45 44	PI/ CI	Reference Clock Input: (Required) A reference clock input used for clock/data recovery and generation. Can be a differential 155.52MHz differential LVPECL Input (Type PI) at CKREFP/N or a single-ended 19.44MHz or 77.78MHz CMOS Input (Type CI) at CKREFP (tie CKREFN to ground when unused).
LOS	33	OD	Loss of Signal (active-high): Standards compatible loss of signal indicator.
PORB	36	A	Power-On Reset (active low): See Power-On Reset description on use of this pin. Do not pull-up to Vcc.

PIN DESCRIPTION (continued)

CONTROL PINS

NAME	PIN	TYPE	DESCRIPTION
LPBK	10	CIT	Loopback Selection: <u>Low:</u> Normal operation <u>Float:</u> Remote Loopback Enable: Recovered receive data and clock are looped back to the transmitter for retransmission. <u>High:</u> Local Loopback Enable: The transmit data is looped back and used as the input to the receiver.
CKMODE	9	CIT	Clock Mode Selection: <u>Low:</u> Reserved <u>Float:</u> Reference clock is <u>synchronous</u> to transmit data. Clock is recovered with a CDR and data is passed through a FIFO <u>High:</u> Reference clock is <u>plesiochronous</u> to transmit data. Clock is recovered with a CDR and the FIFO is bypassed
TXOUT1	56	CIT	Advanced Tx Control 1: <u>Low:</u> Enables fixed LVPECL equalizer at the transmit inputs SIDP/N (for FR4 trace lengths up to 1.5m). <u>Float:</u> Normal operation <u>High:</u> Normal operation
TXOUT0	1	CIT	Advanced Tx Control 0: <u>Low:</u> Nominal amplitude <u>Float:</u> 5% amplitude boost <u>High:</u> 10% amplitude boost
TXPD	8	CID	Transmitter Power Down: When high, powers down and tri-states the transmit driver.
SPSL	32	CID	Serial Port Selection: When high, chip is software controlled through the 4-wire serial port.
CKSL	34	CIT	Reference Clock Frequency Selection: Selects the reference frequency that is supplied at the CKREFP/N pins. Its level is read in at power-up or on the rising edge of a reset signal at the PORB pin. <u>Low:</u> 19.44MHz <u>Float:</u> 77.76MHz <u>High:</u> 155.52MHz

PIN DESCRIPTION (continued)

SERIAL-PORT PINS

NAME	PIN	TYPE	DESCRIPTION
SEN	41	CIU	<p>[SPSL=1] Serial-Port Enable: High during read and write operations. Low disables the serial port. While SEN is low, SDO remains in high impedance state, and SDI and SCK activities are ignored.</p> <p>[SPSL=0] Reserved. Must be tied high</p>
SCK_MON	42	CIS	<p>[SPSL=1] Serial Clock: Controls the timing of SDI and SDO.</p> <p>[SPSL=0] Receive Monitor Mode Enable: When high, adds 20dB of flat gain to the incoming signal before equalization.</p>
SDI	40	CI	<p>[SPSL=1] Serial Data Input: Inputs mode and address information. Also inputs register data during a Write operation. Both address and data are input least significant bit first.</p> <p>[SPSL=0] Reserved. Must be tied low</p>
SDO	39	COZ	<p>[SPSL=1] Serial Data Output: Outputs register information during a Read operation. Data is output least significant bit first</p> <p>[SPSL=0] Must be tied low</p>

POWER AND GROUND PINS

It is recommended that all supply pins be connected to a single power supply plane and all ground pins be connected to a single ground plane.

NAME	PIN	TYPE	DESCRIPTION
VCC	2, 6, 11, 31, 38, 43, 48, 52	S	Power Supply (Vdd)
GND	3, 7, 12, 30, 35, 37, 46, 47, 49, 55	G	Ground

ELECTRICAL SPECIFICATIONS

ABSOLUTE MAXIMUM RATINGS

Operation beyond these limits may permanently damage the device.

PARAMETER	RATING
Supply Voltage (Vdd)	-0.5 to 4.0 VDC
Storage Temperature	-65 to 150 °C
Junction Temperature	-40 to 150 °C
Pin Voltage (CMIP, CMIN)	Vdd + 1.5 VDC
Pin Voltage (all other pins)	-0.3 to (Vdd+0.6) VDC
Pin Current	±100 mA

RECOMMENDED OPERATING CONDITIONS

Unless otherwise noted all specifications are valid over these temperatures and supply voltage ranges.

PARAMETER	RATING
DC Voltage Supply (Vdd)	3.15 to 3.45 VDC
Ambient Operating Temperature	-40 to 85°C
Junction Temperature	-40 to 125°C

DC CHARACTERISTICS:

PARAMETER	SYMBOL	CONDITIONS	MIN	NOM	MAX	UNIT
Supply Current (including transmitter current through transformer)	I _{dd}	Max cable length		160	180	mA
Receive-only Supply Current	I _{ddr}	Transmitter disabled (PDTX=1)		92	106	mA
Power down Current	I _{ddq}	PDTX=1, PDRX=1		7	10	mA

ELECTRICAL SPECIFICATIONS (continued)

ANALOG PINS CHARACTERISTICS:

The following table is provided for informative purpose only. Not tested in production.

PARAMETER	SYMBOL	CONDITIONS	MIN	NOM	MAX	UNIT
RXP and RXN Common-Mode Bias Voltage	Vblin	Ground Reference	1.9		2.6	V
RXP and RXN Differential Input Impedance	Rilin			20		kΩ
Analog Input/Output Capacitance	Cin			8		pF
PORB Input Impedance	--			5		kΩ

DIGITAL I/O CHARACTERISTICS:

Pins of type CI, CID:

PARAMETER	SYMBOL	CONDITIONS	MIN	NOM	MAX	UNIT
Input Voltage Low	Vil				0.8	V
Input Voltage High	Vih		2.0			V
Input Current	Iil, Iih		-1	0	1	μA
Pull-down Resistance	Rpd	Type CID only	40	58	120	kΩ
Input Capacitance	Cin			8		pF

Pins of type CIT:

PARAMETER	SYMBOL	CONDITIONS	MIN	NOM	MAX	UNIT
Input Voltage Low	Vtil				0.4	V
Input Voltage High	Vtih		Vcc-0.6			V
Minimum impedance to be considered as "float" state	Rtiz		30			kΩ

Pins of type CIS:

PARAMETER	SYMBOL	CONDITIONS	MIN	NOM	MAX	UNIT
Low-to-High Threshold	Vt+		1.3		1.7	V
High-to-Low Threshold	Vt-		0.8		1.2	V
Input Current	Iil, Iih		-1		1	μA
Input Capacitance	Cin			8		pF

Pins of type COZ:

PARAMETER	SYMBOL	CONDITIONS	MIN	NOM	MAX	UNIT
Output Voltage Low	Vol	Iol = 8mA			0.4	V
Output Voltage High	Voh	Ioh = -8mA	2.4			V
Output Transition Time	Tt	CL = 20pF, 10-90%			2	ns
Effective Source Impedance	Rscr			30		Ω
Tri-state Output Leakage Current	Iz		-1		1	μA

ELECTRICAL SPECIFICATIONS (continued)

DIGITAL I/O CHARACTERISTICS: (continued)

Pins of type PO:

PARAMETER	SYMBOL	CONDITIONS	MIN	NOM	MAX	UNIT
Signal Swing	V _{pk}		0.5	0.8	1.1	V
Common Mode Level	V _{cm}	V _{dd} referenced	-1.55	-1.2	-1.1	V
Effective Source Impedance	R _{eff}			20		Ω
Rise Time	T _r	10-90%		0.8	1.2	ns
Fall Time	T _f	10-90%		0.8	1.2	ns

Pins of type PI:

PARAMETER	SYMBOL	CONDITIONS	MIN	NOM	MAX	UNIT
Signal Swing	V _{pki}		0.3			V
Common Mode Level	V _{cm}	V _{dd} referenced	-1.6	-1.2	-0.8	V

Pins of type OD

PARAMETER	SYMBOL	CONDITIONS	MIN	NOM	MAX	UNIT
Output Voltage Low	V _{ol}	I _{ol} = 8mA			0.4	V
Pull-down Leakage Current	I _{pd}	Logic high output			1	nA
Pull-up Resistor	R _{pu}		4.7		10	kΩ

REFERENCE CLOCK CHARACTERISTICS:

PARAMETER	SYMBOL	CONDITIONS	MIN	NOM	MAX	UNIT
CKREF Duty Cycle	--		40		60	%
CKREF Frequency Stability	--	Synchronous mode	-20		+20	ppm
		Plesiochronous or Loop-timing mode. (see Note 1)	-75		+75	

Note 1: In Plesiochronous mode, the transmit data source (i.e. framer) must still be of +/-20ppm quality in order to meet SONET/SDH bit rate requirements.

ELECTRICAL SPECIFICATIONS (continued)

SERIAL-PORT TIMING CHARACTERISTICS:

PARAMETER	SYMBOL	CONDITIONS	MIN	TYP	MAX	UNIT
SDI to SCK setup time	t_{su}		4			ns
SDI to SCK hold time	t_h		4			ns
SCK to SDO propagation delay	t_{prop}				10	ns
SCK Frequency	SCK				20	MHz

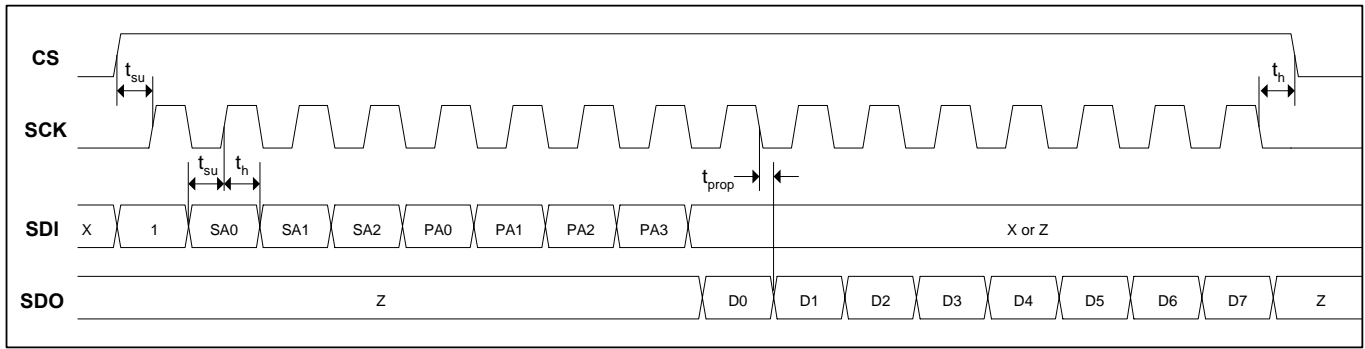

Figure 6: Read Operation

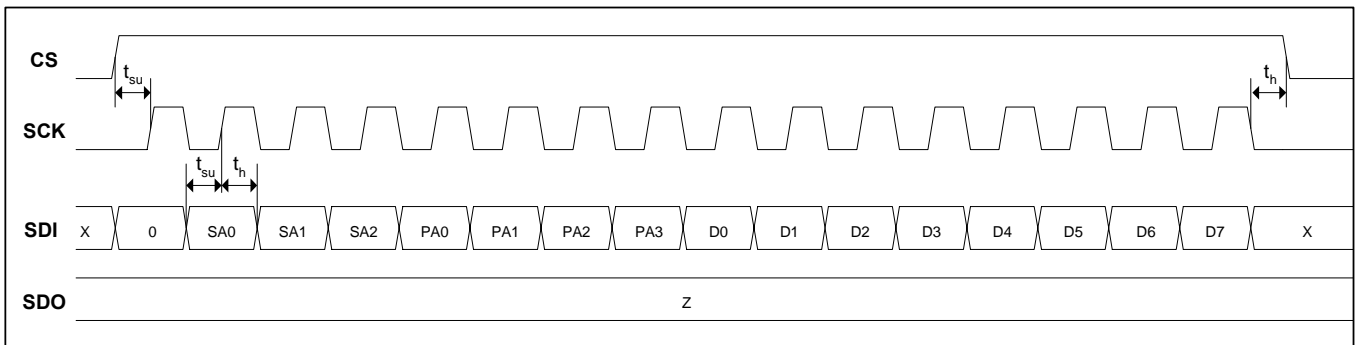

Figure 7: Write Operation

ELECTRICAL SPECIFICATIONS (continued)

TRANSMITTER SPECIFICATIONS FOR CMI INTERFACE

Bit Rate: 155.52Mbits/s \pm 20ppm

Code: Coded Mark Inversion (CMI)

Relevant Specification: ITU-T G.703, Telcordia GR-253, ANSI T1.102

With the coaxial output port driving a 75 Ω load, the output pulses conform to the templates in Figures 8 and 9. These specifications are tested during production test. Consult application note for reference schematic, layout guidelines, and recommended transformers.

PARAMETER	CONDITION	MIN	NOM	MAX	UNIT
Peak-to-peak Output Voltage (Fuse-trimmed to nominal target at final test)	Template, steady state	0.9	1.04	1.1	V
Rise/ Fall Time	10-90%			2	ns
Transition Timing Tolerance	Negative Transitions	-0.1		0.1	ns
	Positive Transitions at Interval Boundaries	-0.5		0.5	
	Positive Transitions at mid-interval	-0.35		0.35	

The following specifications are not tested during production test. They are included for information only.

Note that the return loss depends on the board layout and the particular transformer used.

PARAMETER	CONDITION	MIN	NOM	MAX	UNIT
Output Impedance	Driver is open drain		1 8		M Ω pF
Return Loss	7MHz to 240MHz	15			dB

ELECTRICAL SPECIFICATIONS (continued)

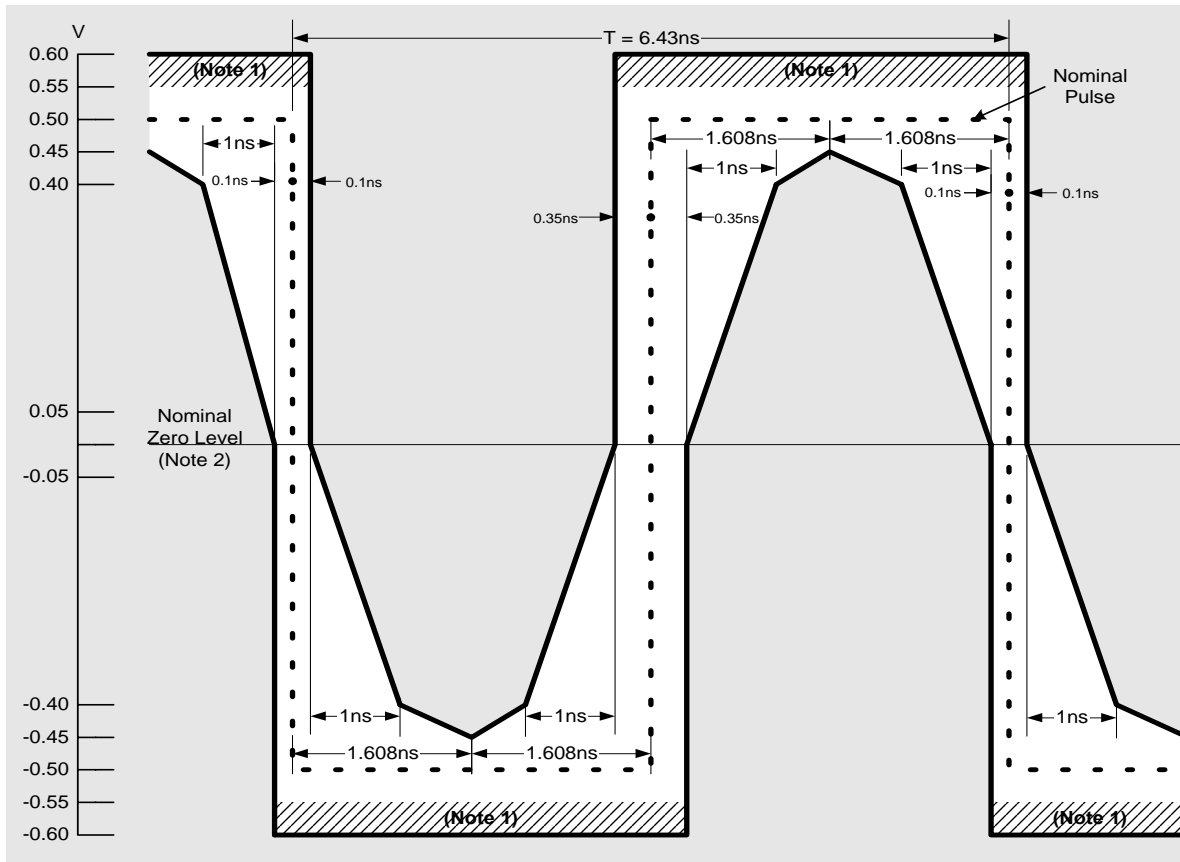

Note 1 – The maximum “steady state” amplitude should not exceed the 0.55V limit. Overshoots and other transients are permitted to fall into the shaded area bounded by the amplitude levels 0.55V and 0.6V, provided that they do not exceed the steady state level by more than 0.05V.

Note 2 – For all measurements using these masks, the signal should be AC coupled, using a capacitor of not less than 0.01 μ F, to the input of the oscilloscope used for measurements. The nominal zero level for both masks should be aligned with the oscilloscope trace with no input signal. With the signal then applied, the vertical position of the trace can be adjusted with the objective of meeting the limits of the masks. Any such adjustment should be the same for both masks and should not exceed ± 0.05 V. This may be checked by removing the input signal again and verifying that the trace lies with ± 0.05 V of the nominal zero level of the masks.

Note 3 – Each pulse in a coded pulse sequence should meet the limits of the relevant mask, irrespective of the state of the preceding or succeeding pulses, with both pulse masks fixed in the same relation to a common timing reference, i.e. with their nominal start and finish edges coincident. The masks allow for HF jitter caused by intersymbol interference in the output stage, but not for jitter present in the timing signal associated with the source of the interface signal. When using an oscilloscope technique to determine pulse compliance with the mask, it is important that successive traces of the pulses overlay in order to suppress the effects of low frequency jitter. This can be accomplished by several techniques [e.g. a) triggering the oscilloscope on the measured waveform or b) providing both the oscilloscope and the pulse output circuits with the same clock signal].

Note 4 – For the purpose of these masks, the rise time and decay time should be measured between -0.4 V and 0.4 V, and should not exceed 2ns.

Figure 8 – Mask of a Pulse corresponding to a binary Zero.

ELECTRICAL SPECIFICATIONS (continued)

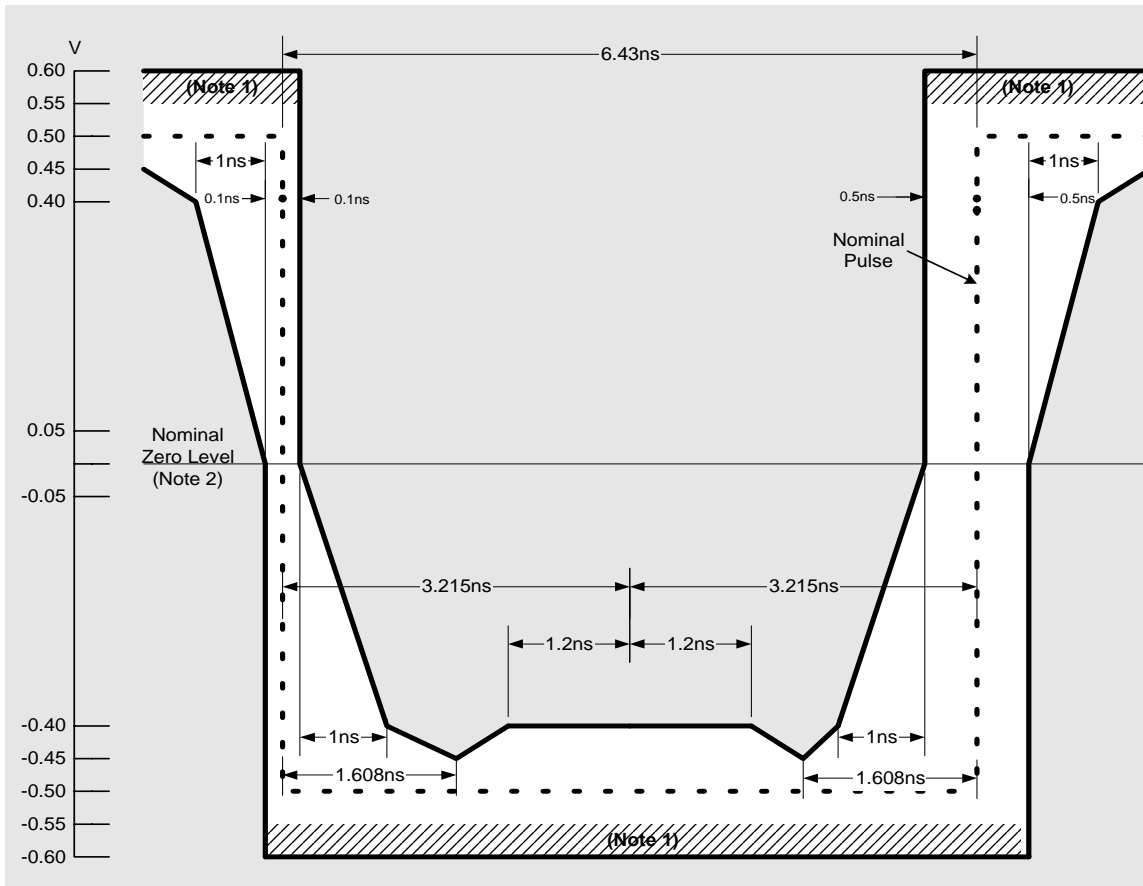

Note 1 – The maximum “steady state” amplitude should not exceed the 0.55V limit. Overshoots and other transients are permitted to fall into the shaded area bounded by the amplitude levels 0.55V and 0.6V, provided that they do not exceed the steady state level by more than 0.05V.

Note 2 – For all measurements using these masks, the signal should be AC coupled, using a capacitor of not less than 0.01 μ F, to the input of the oscilloscope used for measurements. The nominal zero level for both masks should be aligned with the oscilloscope trace with no input signal. With the signal then applied, the vertical position of the trace can be adjusted with the objective of meeting the limits of the masks. Any such adjustment should be the same for both masks and should not exceed ± 0.05 V. This may be checked by removing the input signal again and verifying that the trace lies with ± 0.05 V of the nominal zero level of the masks.

Note 3 – Each pulse in a coded pulse sequence should meet the limits of the relevant mask, irrespective of the state of the preceding or succeeding pulses, with both pulse masks fixed in the same relation to a common timing reference, i.e. with their nominal start and finish edges coincident. The masks allow for HF jitter caused by intersymbol interference in the output stage, but not for jitter present in the timing signal associated with the source of the interface signal. When using an oscilloscope technique to determine pulse compliance with the mask, it is important that successive traces of the pulses overlay in order to suppress the effects of low frequency jitter. This can be accomplished by several techniques [e.g. a) triggering the oscilloscope on the measured waveform or b) providing both the oscilloscope and the pulse output circuits with the same clock signal].

Note 4 – For the purpose of these masks, the rise time and decay time should be measured between -0.4 V and 0.4 V, and should not exceed 2ns.

Note 5 – The inverse pulse will have the same characteristics, noting that the timing tolerance at the level of the negative and positive transitions are ± 0.1 ns and ± 0.5 ns respectively.

Figure 9 – Mask of a Pulse corresponding to a binary One

ELECTRICAL SPECIFICATIONS (continued)

TRANSMITTER OUTPUT JITTER

The transmit jitter specification ensures compliance with ITU-T G.813, G.823, G.825 and G.958; ANSI T1.102-1993 and T1.105.03-1994; and GR-253-CORE for all supported rates. Transmit output jitter is not tested during production test.

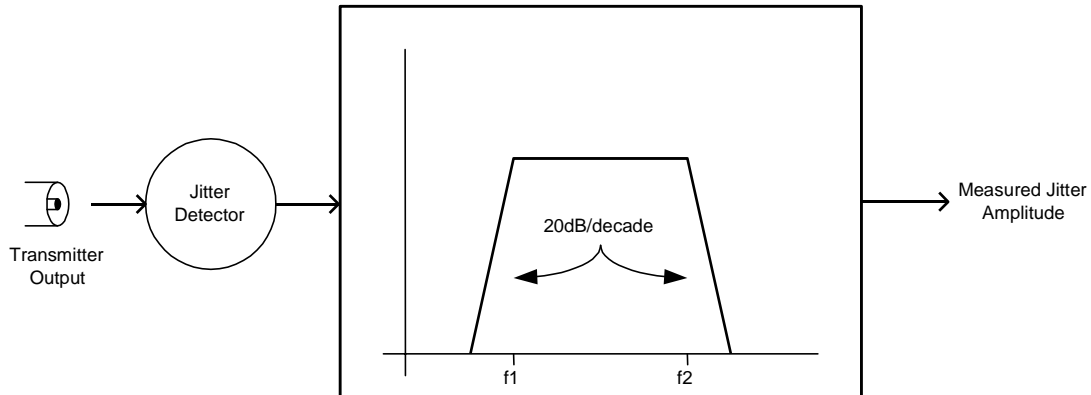

PARAMETER	CONDITION	MIN	NOM	MAX	UNIT
Transmitter Output Jitter	200 Hz to 3.5 MHz, measured with respect to CKREF for 60s			0.075	UIpp

ELECTRICAL SPECIFICATIONS (continued)

RECEIVER SPECIFICATIONS FOR CMI INTERFACE (Transformer-coupled)

Consult application notes for reference schematic, layout guidelines, and recommended transformers.

PARAMETER	CONDITION	MIN	TYP	MAX	UNIT
Peak Differential Input Amplitude, RXP and RXN	MON=0. 12.7dB of cable loss	70		550	mVpk
Peak Differential Input Amplitude, RXP and RXN	MON=1. 20dB flat loss with 6dB cable loss (max)	25		80	mVpk
Flat-loss Tolerance	MON=0. All valid cable lengths.	-2		4	dB
Latency			5	10	UI
PLL Lock Time			1	10	μs
Return Loss	7MHz to 240MHz	15			dB

The input signal is assumed compliant with ITU-T G.703 and can be attenuated by the dispersive loss of a cable. The minimum cable loss is 0dB and the maximum is -12.7dB at 78MHz.

The “Worst Case” line corresponds to the ITU-T G.703 recommendation. The “Typical” line corresponds to a typical installation referred to in ANSI T1.102-1993. The receiver is tested using the cable model. It is a lumped element approximation of the “Worst Case” line.

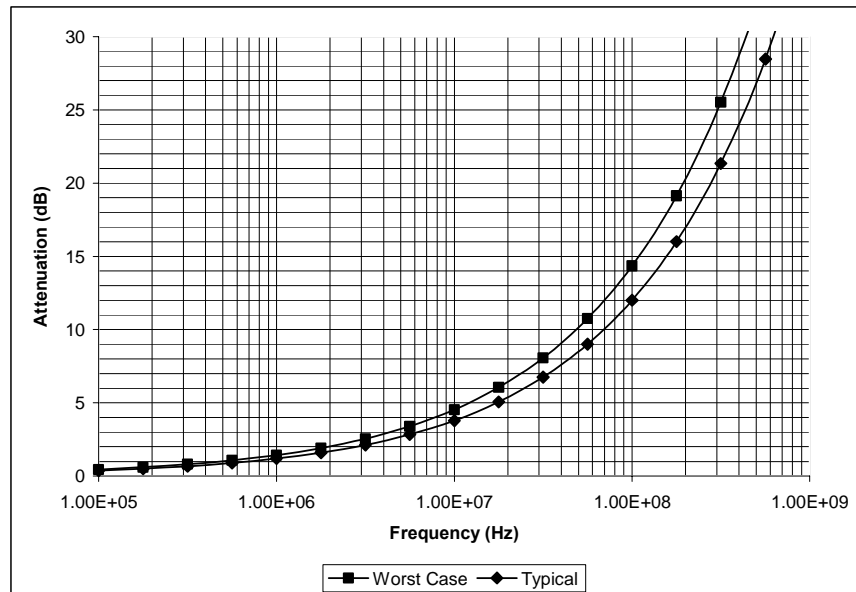

Figure 10: Typical and worst-case Cable attenuation

ELECTRICAL SPECIFICATIONS (continued)

RECEIVER JITTER TOLERANCE

The 78P2351R exceeds all relevant jitter tolerance specifications shown in Figure 11. STM-1e (electrical) jitter tolerance specifications are in ITU-T G.825. Receive jitter tolerance is not tested during production test.

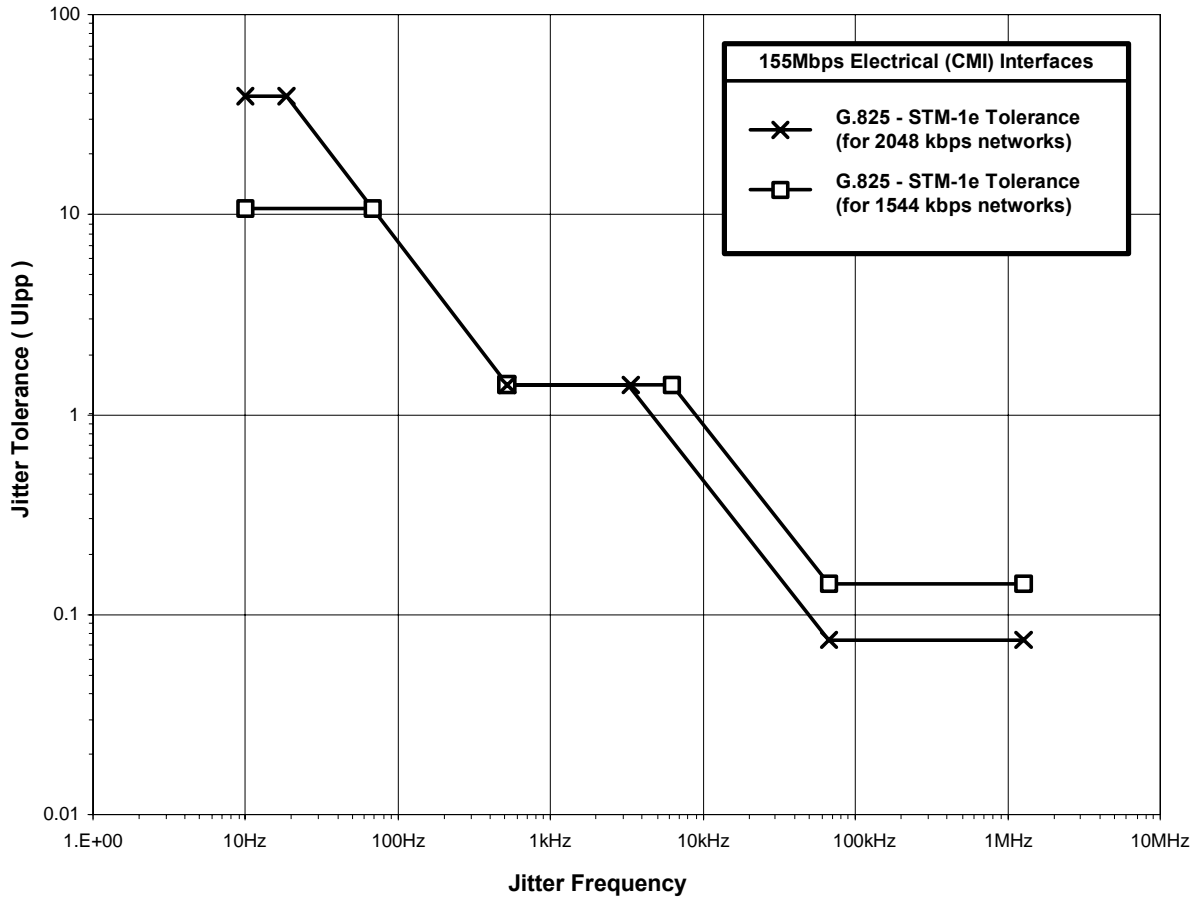

Figure 11: Jitter Tolerance - electrical (CMI) interfaces

PARAMETER	CONDITION	MIN	NOM	MAX	UNIT
STM-1e Jitter Tolerance	10Hz to 19.3Hz	38.9			UIpp
	19.3Hz to 500Hz		750 f-1		μs
	500Hz to 6.5kHz	1.5			UIpp
	6.5kHz to 65kHz		9800 f-1		μs
	65kHz to 1.3MHz	0.15			UIpp

ELECTRICAL SPECIFICATIONS (continued)

RECEIVER JITTER TRANSFER FUNCTION

The receiver clock recovery loop filter characteristics such that the receiver has the following transfer function. The corner frequency of the Rx DLL is approximately 120 kHz. Receiver jitter transfer function is not tested during production test.



Figure 12: Jitter Transfer

PARAMETER	CONDITION	MIN	NOM	MAX	UNIT
Receiver Jitter transfer function	below 120 kHz			0.1	dB
Jitter transfer function roll-off			20		dB per decade

ELECTRICAL SPECIFICATIONS (continued)

LOSS OF SIGNAL CONDITION

PARAMETER	CONDITION	MIN	TYP	MAX	UNIT
LOS threshold		-35	-19	-15	dB
LOS timing		10	110	255	UI

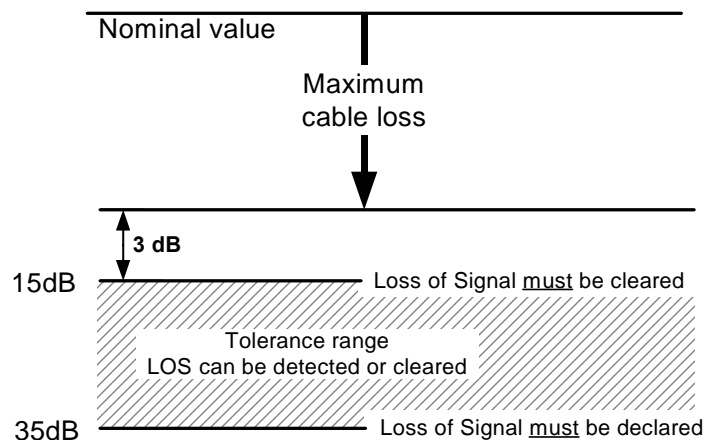

APPLICATION INFORMATION

EXTERNAL COMPONENTS:

COMPONENT	PIN(S)	VALUE	UNITS	TOLERANCE
Receiver Termination Resistor	RXP RXN	75	Ω	1%
Transmitter Termination Resistor	CMIP CMIN	75	Ω	1%

TRANSFORMER SPECIFICATIONS:

COMPONENT	VALUE	UNITS	TOLERANCE
Turns Ratio for the Receiver		1:1	
Turns Ratio for the Transmitter (center-tapped)		1:1CT	

Suggested Manufacturers: Halo, MiniCircuits, Tamura, Belfuse

THERMAL INFORMATION:

PACKAGE	CONDITIONS	Θ_{JA} (°C/W)	Θ_{JC} (°C/W)
Standard 56-pin JEDEC QFN	No forced air; 4-layer JEDEC test board	46.8	16.6
	No forced air; 4-layer JEDEC test board Die attach pad soldered to PCB	23.5	15.6

SCHEMATICS

For reference schematics, layout guidelines, suggested transformer part numbers, etc. please check Teridian Semiconductor's website or contact your local sales representative for the latest application note(s) and/or evaluation boards.

MECHANICAL SPECIFICATIONS

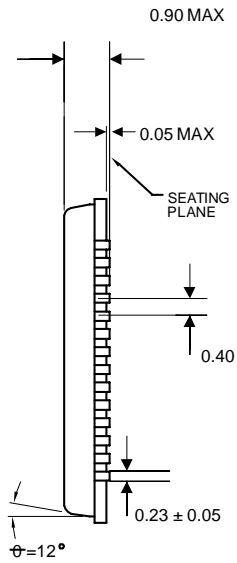

SIDE VIEW

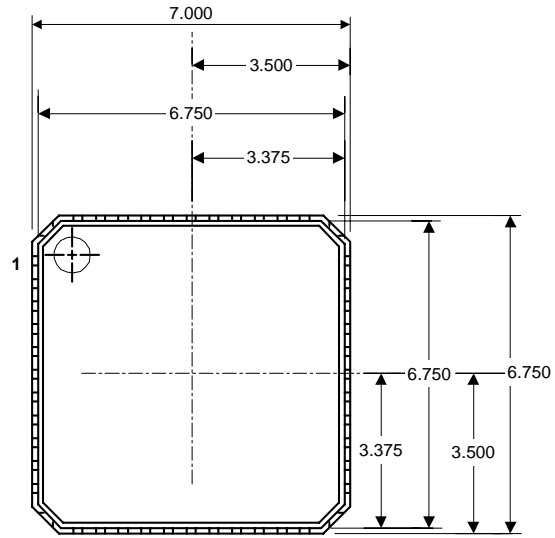

TOP VIEW

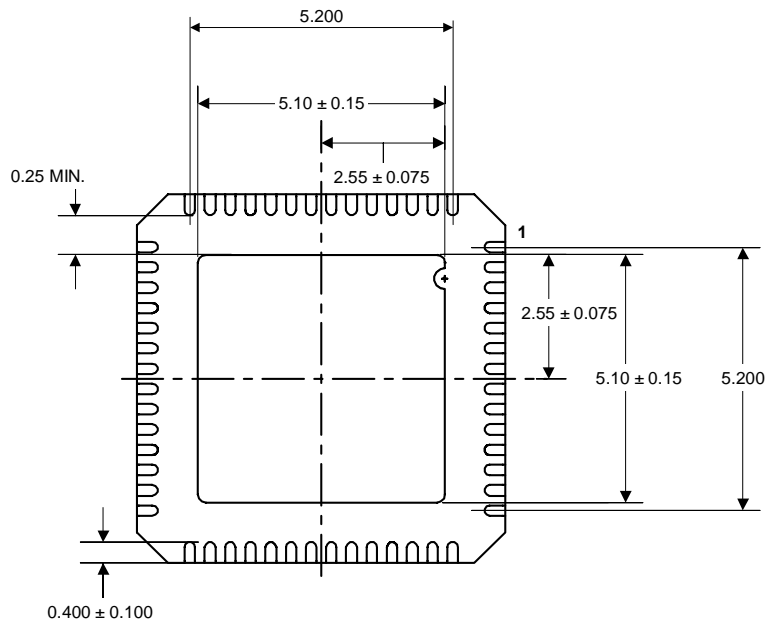

BOTTOM VIEW

56-pin Quad Flat No-lead package (QFN)
(All dimensions in mm)

Revision History	
--	Contact Teridian for revision history of earlier releases
v2-0	August 15, 2005: Final Datasheet Release <ul style="list-style-type: none"> ▪ Updated Ordering Numbers to reflect production silicon revision A06 ▪ Improved/modified Functional Descriptions ▪ Improved/modified Register Descriptions <ul style="list-style-type: none"> ▪ Added FLBK bit ▪ Removed Rx LOL bit ▪ Improved/modified Pin Descriptions ▪ Updated Electrical Specification min/max limits for: <ul style="list-style-type: none"> ▪ DC Characteristics, ▪ CID, CIU, CIT, and PO pin types ▪ CMI Loss of Signal Conditions ▪ Changed name and logo from TDK to Teridian

If and when manufactured and sold, this product is sold subject to the terms and conditions of sale supplied at the time of order acknowledgment, including those pertaining to warranty, patent infringement and limitation of liability. Teridian Semiconductor Corporation (TSC) reserves the right to make changes in specifications at any time without notice. Accordingly, the reader is cautioned to verify that a data sheet is current before placing orders. TSC assumes no liability for applications assistance.

Teridian Semiconductor Corp., 6440 Oak Canyon Rd., Irvine, CA 92618
 TEL (714) 508-8800, FAX (714) 508-8877, <http://www.teridian.com>