



### FEATURES

- 3V to 30V Input Voltage Operation.
- Internal 1.6A Peak Current Switch.
- Internal  $\pm 1.8\%$  Reference.
- Low Quiescent Current at 1.6mA.
- Frequency Operation from 100Hz to 100KHz.
- Current Limiting.

### APPLICATIONS

- Saver for Cellular phones
- DC-DC Converter Module

### DESCRIPTION

The MC34063A by Analog Integrations Corporation, an improved second source over the industrial standard MC34063A, is a monolithic control circuit containing the primary functions required for DC/DC converters. The device consists of an internal temperature compensated reference, comparator, controlled duty cycle oscillator with an active current limit circuit, driver and high current output switch. This device is specifically designed to be incorporated in step-down, step-up and voltage-inverting applications with a minimum number of external components. The  $\pm 1.8\%$  internal reference and low quiescent current of 1.6mA are among the improvements of the device over the competition.

### TYPICAL APPLICATION CIRCUIT

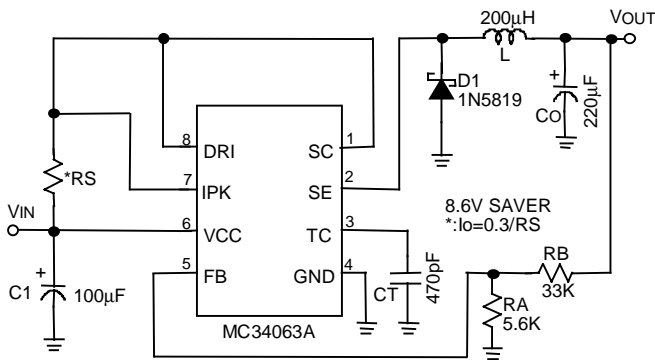

Saver Circuit for Cellular Phone

### ORDERING INFORMATION

MC34063A XX

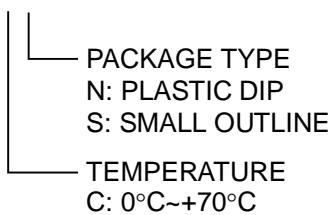

ORDER NUMBER	PIN CONFIGURATION
MC34063ACN (PLASTIC DIP)	TOP VIEW 
MC34063ACS (PLASTIC SO)	



**■ ABSOLUTE MAXIMUM RATINGS**

Supply Voltage	30V
Comparator Input Voltage Range	-0.3V~30V
Switch Collector Voltage	30V
Switch Emitter Voltage	30V
Switch Collector to Emitter Voltage	30V
Driver Collector Voltage	30V
Switch Current	1.6A
Power Dissipation and Thermal Characteristics	
<b>DIP Package</b>	
Ta= 25°C	1.0W
Thermal Resistance	100°C/W
<b>SO Package</b>	
Ta= 25°C	625mW
Thermal Resistance	160°C/W
Operating Junction Temperature	125°C
Operating Ambient Temperature Range	0°C~70°C
Storage Temperature Range	- 65°C~150°C



**ELECTRICAL CHARACTERISTICS (VCC= 5V, Ta=25°C, unless otherwise specified.)**

PARAMETER	TEST CONDITIONS	SYMBOL	MIN.	TYP.	MAX.	UNIT
<b>Oscillator</b>						
Charging Current	5.0V≤VCC≤30V	I <sub>CHG</sub>	10	25	40	μA
Discharge Current	5.0V≤VCC≤30V	I <sub>DISCHG</sub>	100	150	200	μA
Voltage Swing	PIN 3	V <sub>OSC</sub>		0.6		V
Discharge to Charge Current Ratio	V <sub>IPK(SENSE)</sub> =VCC	I <sub>DISCHG</sub> / I <sub>CHG</sub>		6.0		
Current Limit Sense Voltage	I <sub>CHG</sub> =I <sub>DISCHG</sub>	V <sub>IPK(SENSE)</sub>	250	300	350	mV
<b>Output Switch</b>						
Saturation Voltage, Darlington Connection	I <sub>SW</sub> =1.0A; V <sub>C(DRIVER)</sub> =V <sub>C(SWITCH)</sub>	V <sub>CE(SAT)</sub>		1.0	1.3	V
Saturation Voltage	I <sub>SW</sub> =1.0A; I <sub>C(DRIVER)</sub> =50mA (Forced β≈20)	V <sub>CE(SAT)</sub>		0.4	0.7	V
DC Current Gain	I <sub>SW</sub> =1.0A; V <sub>CE</sub> =5.0V	h <sub>FE</sub>	35	120		
Collector Off-State Current	V <sub>CE</sub> =30V	I <sub>C(OFF)</sub>		10		nA
<b>Comparator</b>						
Threshold Voltage	0°C≤Ta≤70°C	V <sub>FB</sub>	1.227	1.25	1.273	V
Threshold Voltage			1.21		1.29	V
Threshold Voltage Line Regulation	3.0V≤VCC≤30V	REG <sub>LINE</sub>		0.1	0.3	mV/V
Input Bias Current	V <sub>IN</sub> =0V	I <sub>IB</sub>		0.4	1	μA
Supply current	V <sub>IPK(SENSE)</sub> =VCC V <sub>PIN 5</sub> >V <sub>FB</sub> 5.0V≤VCC≤30V C <sub>T</sub> =0.001μF, PIN 2=GND Remaining pins open	I <sub>CC</sub>		1.6	3	mA



**TYPICAL PERFORMANCE CHARACTERISTICS**

Output Switch ON-OFF Time vs. Oscillator Timing Capacitor

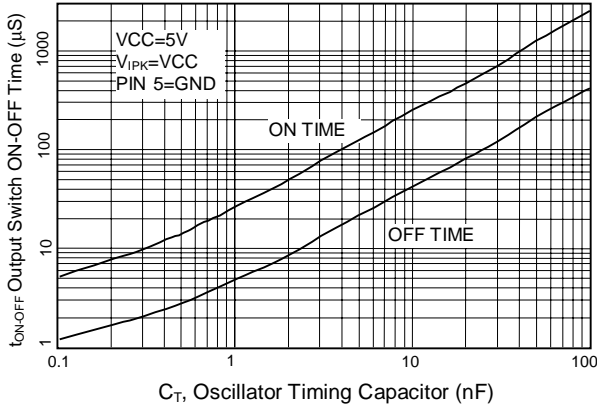

Standby Supply Current vs. Supply Voltage

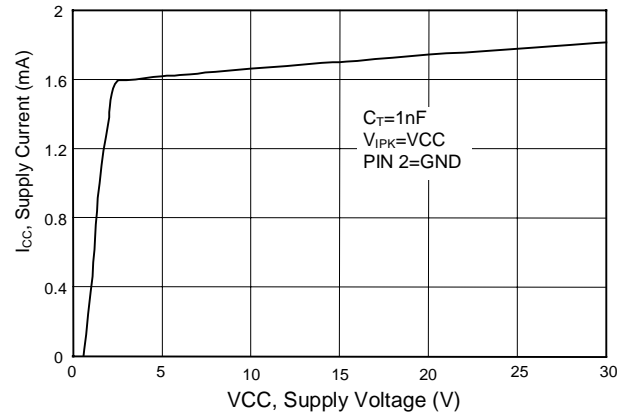

VFB, Threshold Voltage vs Temperature

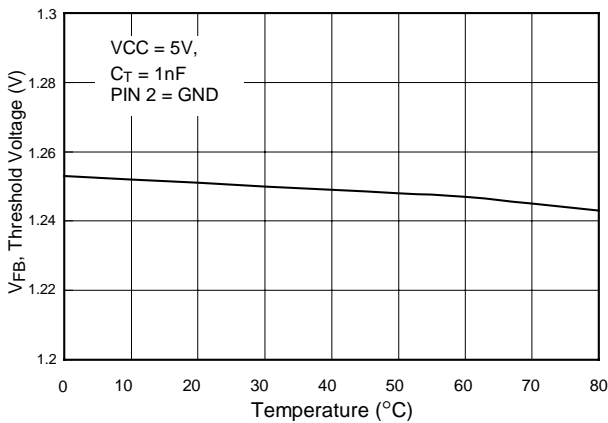

IPK Threshold Voltage vs Temperature

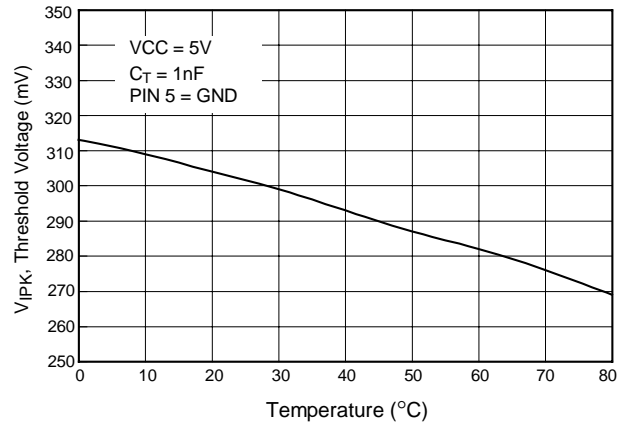

Emmitter-Follower Configuration Output Switch Saturation Voltage vs Emmitter Current

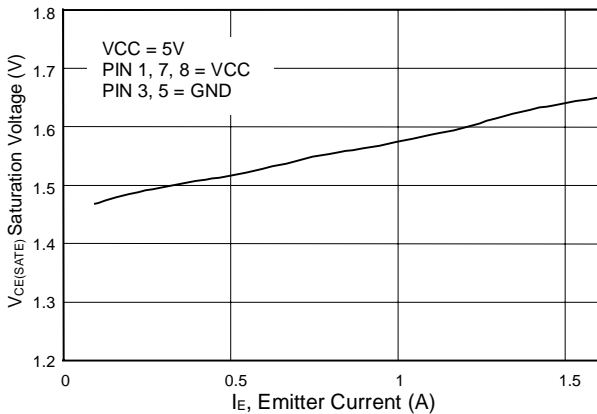

Common-Emitter Configuration Output Switch Saturation Voltage vs Collector Current

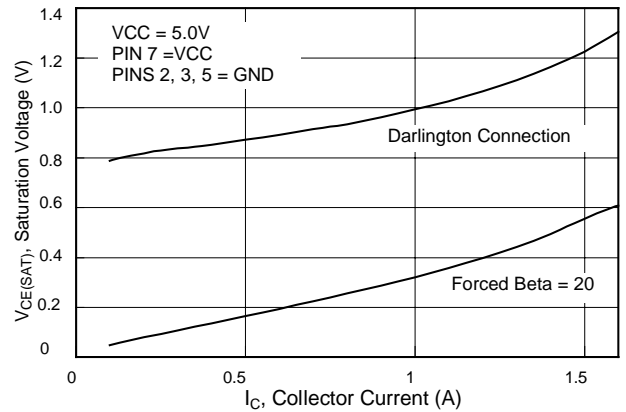



**BLOCK DIAGRAM**

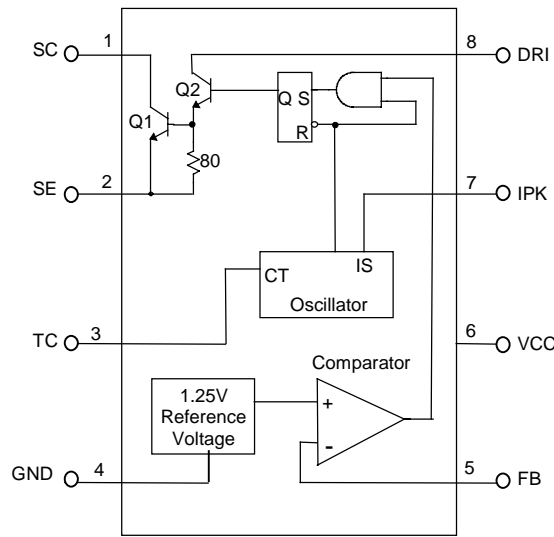

**PIN DESCRIPTIONS**

- PIN 1: SC - 1.6A switch collector
- PIN 2: SE - Darlington switch emitter
- PIN 3: TC - Oscillator timing capacitor
- PIN 4: GND - Power GND
- PIN 5: FB - Feedback comparator inverting input
- PIN 6: VCC - Power supply input
- PIN 7: IPK - Highside current sense input, VCC - V<sub>IPK</sub>=300mV
- PIN 8: DRI - Drive collector

**APPLICATION INFORMATION**

**DESIGN FORMULA TABLE**

CALCULATION	STEP-DOWN	STEP-UP	VOLTAGE-INVERTING
$\frac{t_{ON}}{t_{OFF}}$	$\frac{V_{OUT} + V_F}{V_{IN(MIN)} - V_{SAT} - V_{OUT}}$	$\frac{V_{OUT} + V_F - V_{IN(MIN)}}{V_{IN(MIN)} - V_{SAT}}$	$\frac{ V_{OUT}  + V_F}{V_{IN} - V_{SAT}}$
$(t_{ON} + t_{OFF})_{MAX}$	$\frac{1}{F_{MIN}}$	$\frac{1}{F_{MIN}}$	$\frac{1}{F_{MIN}}$
C <sub>T</sub>	$4 \times 10^{-5} t_{ON}$	$4 \times 10^{-5} t_{ON}$	$4 \times 10^{-5} t_{ON}$
I <sub>C (SWITCH)</sub>	$2 I_{OUT(MAX)}$	$2 I_{OUT(MAX)} \left( \frac{t_{ON} + t_{OFF}}{t_{OFF}} \right)$	$2 I_{OUT(MAX)} \left( \frac{t_{ON} + t_{OFF}}{t_{OFF}} \right)$
RS	$0.33 / I_{C(SWITCH)}$	$0.33 / I_{C(SWITCH)}$	$0.33 / I_{C(SWITCH)}$
L(MIN)	$\left( \frac{V_{IN(MIN)} - V_{SAT} - V_{OUT}}{I_{C(SWITCH)}} \right) t_{ON(MAX)}$	$\left( \frac{V_{IN(MIN)} - V_{SAT}}{I_{C(SWITCH)}} \right) t_{ON(MAX)}$	$\left( \frac{V_{IN(MIN)} - V_{SAT}}{I_{C(SWITCH)}} \right) t_{ON(MAX)}$
Co	$\frac{I_{C(SWITCH)} (t_{ON} + t_{OFF})}{8 V_{RIPPLE(P-P)}}$	$\frac{I_{OUT} t_{ON}}{V_{RIPPLE(P-P)}}$	$\frac{I_{OUT} t_{ON}}{V_{RIPPLE(P-P)}}$



$V_{SAT}$  = Saturation voltage of the output switch.  
 $V_F$  = Forward voltage drop of the ringback rectifier

$F_{MIN}$  - Minimum desired output switching frequency at the selected values for  $V_{IN}$  and  $I_{OUT}$ .

The following power supply characteristics must be chosen:

- $V_{IN}$  - Nominal input voltage.
- $V_{OUT}$  - Desired output voltage,  
 $|V_{OUT}| = 1.25 (1 + RB/RA)$
- $I_{OUT}$  - Desired output current.

$V_{RIPPLE (P-P)}$  - Desired peak-to-peak output ripple voltage. In practice, the calculated value will need to be increased due to the capacitor equivalent series resistance and board layout. The ripple voltage should be kept to a low value since it will directly effect the line and load regulation.

### APPLICATION EXAMPLES

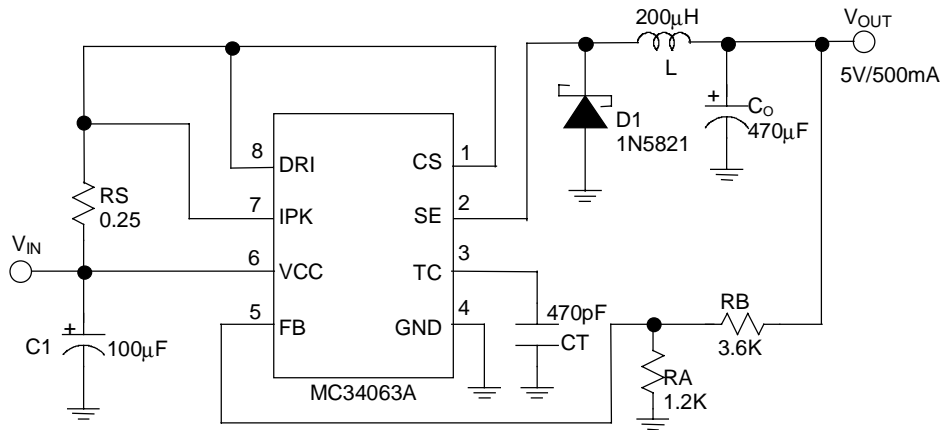

Line Regulation	$V_{IN} = 10V \sim 20V @ I_o=500mA$	40mV
Load Regulation	$V_{IN} = 15V, @ I_o=10mA \sim 500mA$	5mV
Short Circuit Current	$V_{IN} = 15V, @ R_L = 0.1\Omega$	1.3A

Fig. 1 Step-Down Converter

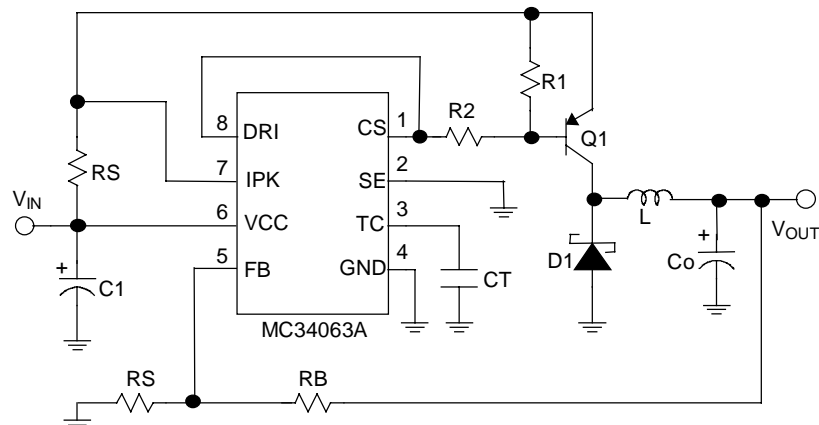
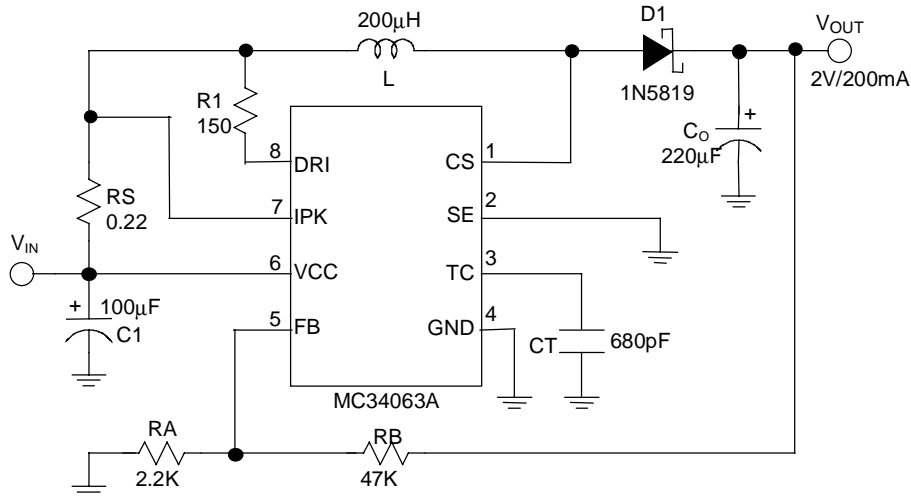

Fig. 2 Step-Down Converter with External PNP Saturation Switch



APPLICATION EXAMPLES (CONTINUED)



Line Regulation	$V_{IN} = 8V \sim 16V @ I_o = 200mA$	100mV
Load Regulation	$V_{IN} = 12V, @ I_o = 80mA \sim 200mA$	5mV

Fig. 3 Step-Up Converter

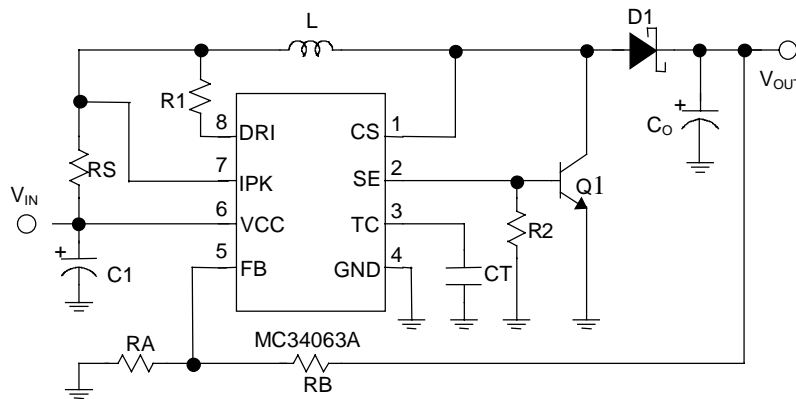
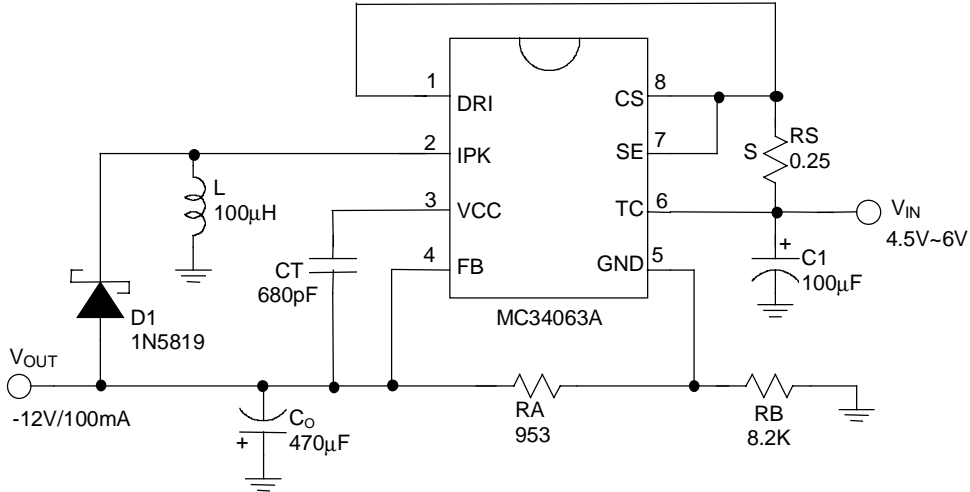

Fig. 4 Step-Up Converter with External NPN Switch



APPLICATION EXAMPLES (CONTINUED)



Line Regulation	$V_{IN} = 4.5V \sim 6V @ I_o = 100mA$	20mV
Load Regulation	$V_{IN} = 5V, @ I_o = 10mA \sim 100mA$	100mV

Fig.5 Inverting Converter

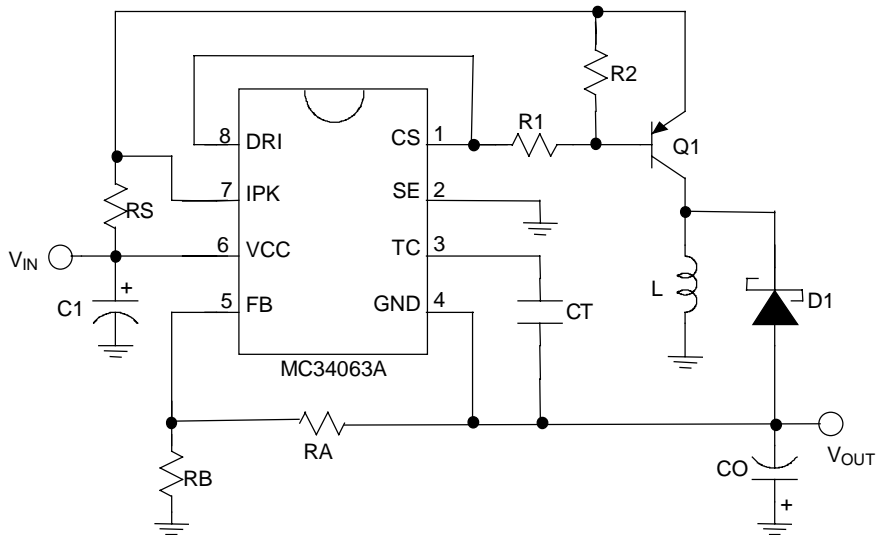
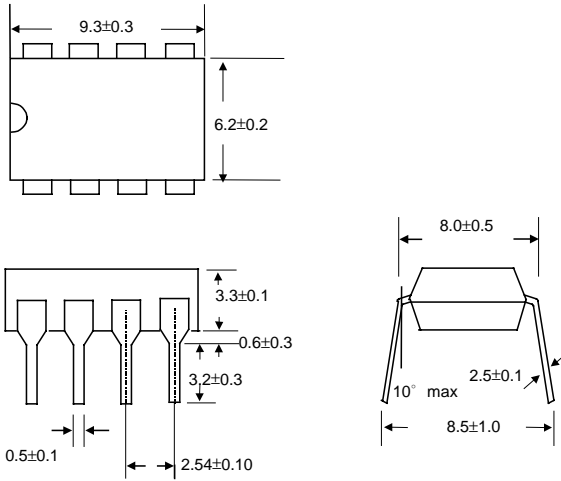

Fig 6. Voltage Inverting Converter With PNP Saturated Switch



■ PHYSICAL DIMENSIONS

● 8 LEAD PLASTIC DIP



● 8 LEAD PLASTIC SO

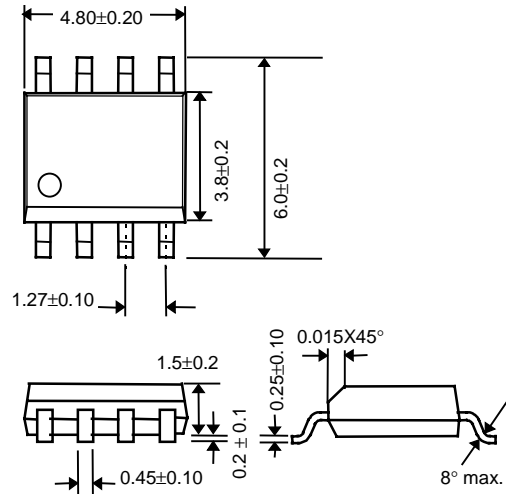

UNIT: mm