



### FEATURES

- Only Two External Components Required Other than the Photodiode.
- Easy to Integrate into Module due to Small Chip Size.
- Minimized Chances of Malfunction Due to Ambient Light.
- Low Power Consumption.
- Center Frequency of Band Pass Filter Adjustable by an External Resistor.
- Microcomputer Compatible.

### APPLICATIONS

- IR Remote Control Receivers for Consumer Electronic Products, such as TVs, VCRs, VCD/DVD Players, Audio Devices, Air Conditioners, Electric Fans...etc.

### DESCRIPTION

The AIC1863 is a high performance infrared remote control preamplifier. Especially, it has excellent interference suppression capability. The infrared pulses arriving at the photodiode are treated by the trans-impedance amplifier and amplified by the auto-gain control amplifier, limiter amplifier, and band-pass filter. The following evaluation circuits, including the comparator, integrator, and schmitt-trigger, demodulate the transmitted digital signal. Reduction of sensitivity due to external interference is achieved by the short-time boost and long-time control circuits, which prevent interference voltages from affecting the output.

### TYPICAL APPLICATION CIRCUIT

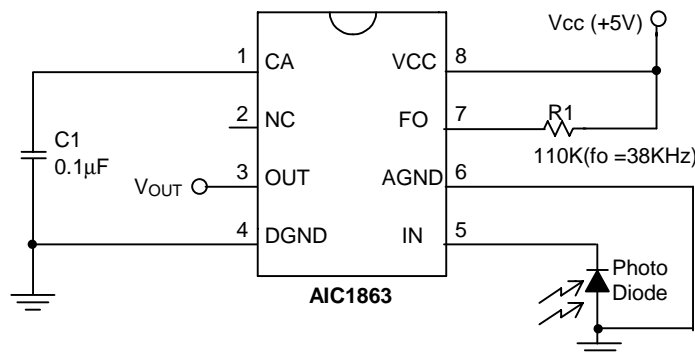

IR Remote Control Receiver

### ORDERING INFORMATION

AIC1863 XX

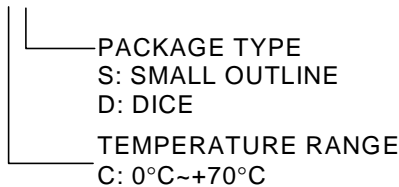

ORDER NUMBER	PIN CONFIGURATION
AIC1863CS (PLASTIC SO)	TOP VIEW 
AIC1863CD (DICE)	



**ABSOLUTE MAXIMUM RATINGS**

Supply Voltage	.....	5.5V
Input Voltage	.....	5 Vp-p
Operating Temperature Range	.....	-20°C~80°C
Storage Temperature Range	.....	- 65°C~ 150°C

**TEST CIRCUIT**

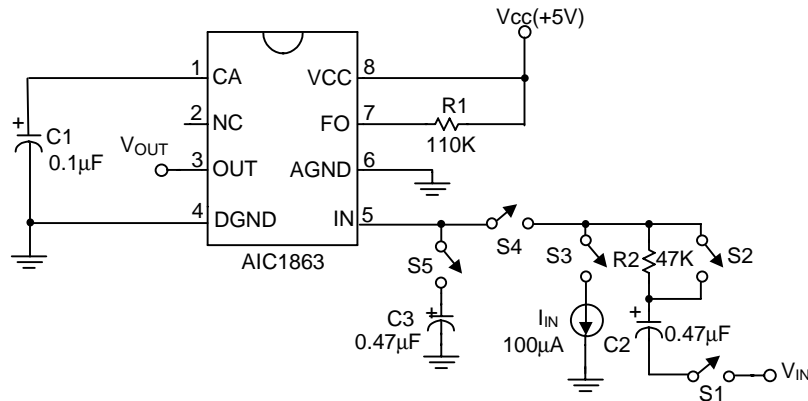

**ELECTRICAL CHARACTERISTICS (VCC= 5V, Ta=25°C, unless otherwise specified.)**

PARAMETER	TEST CONDITIONS	SYMBOL	MIN.	TYP.	MAX.	UNIT
Supply Voltage		V <sub>CC</sub>	4.5	5.0	5.5	V
Input Pin Voltage (1)	I <sub>IN</sub> =0µA	V <sub>IN1</sub>	3.8	4.2	4.4	V
Input Pin Voltage (2)	I <sub>IN</sub> =100µA	V <sub>IN2</sub>	1.5	2.1	2.7	V
Low Level Output Voltage		V <sub>OL</sub>		0.1	0.3	V
High Level Output Voltage		V <sub>OH</sub>	4.70	4.94		V
Voltage Gain	100µV <sub>P-P</sub> , 38KHz	A <sub>V</sub>	76	81		dB
BPF Characteristics	100µV <sub>P-P</sub> , 28KHz, 35KHz, 41KHz, 48KHz (note 1)	A <sub>Q</sub>	4	9		dB
Input Impedance	0.5V <sub>P-P</sub> , 38KHz (note 2)	R <sub>IN</sub>	4	11		KΩ
Detecting Ability (1)	100µV <sub>P-P</sub> , 38KHz 600µS ON Time, 0.2 Duty Cycle	T <sub>D1</sub>	360	520	680	µS



**ELECTRICAL CHARACTERISTICS (Continued)**

PARAMETER	TEST CONDITIONS	SYMBOL	MIN.	TYP.	MAX.	UNIT
Detecting Ability (2)	50mV <sub>P-P</sub> , 38KHz 600μS ON Time, 0.2 Duty Cycle	T <sub>D2</sub>	540	670	800	μS
Switch On Delay Time	100μV <sub>P-P</sub> , 38KHz 600μS ON Time, 0.2 Duty Cycle	T <sub>ON</sub>	100	250	400	μS
Switch Off Delay Time	100μV <sub>P-P</sub> , 38KHz 600μS ON Time, 0.2 Duty Cycle	T <sub>OFF</sub>	150	220	400	μS
LCC Slew Rate	C1=0.1μF	dv/dt		0.8		V/S
Quiescent Current		I <sub>CC</sub>	0.4	0.7	1.0	mA

NOTE 1: Ratio of the AC level at 35KHz and the AC level at 28KHz denotes A<sub>Q1</sub>.

$$A_{Q1} = 20 \log \frac{\text{measured value (f = 35KHz)}}{\text{measured value (f = 28KHz)}}$$

Ratio of the AC level at 41KHz and the AC level at 48KHz denotes A<sub>Q2</sub>.

$$A_{Q2} = 20 \log \frac{\text{measured value (f = 41KHz)}}{\text{measured value (f = 48KHz)}}$$

NOTE 2: Input level denotes V<sub>I</sub> and measured level denotes V<sub>X</sub>, then

$$R_{IN} = \frac{47K\Omega}{V_I / V_X - 1}$$

**BLOCK DIAGRAM**

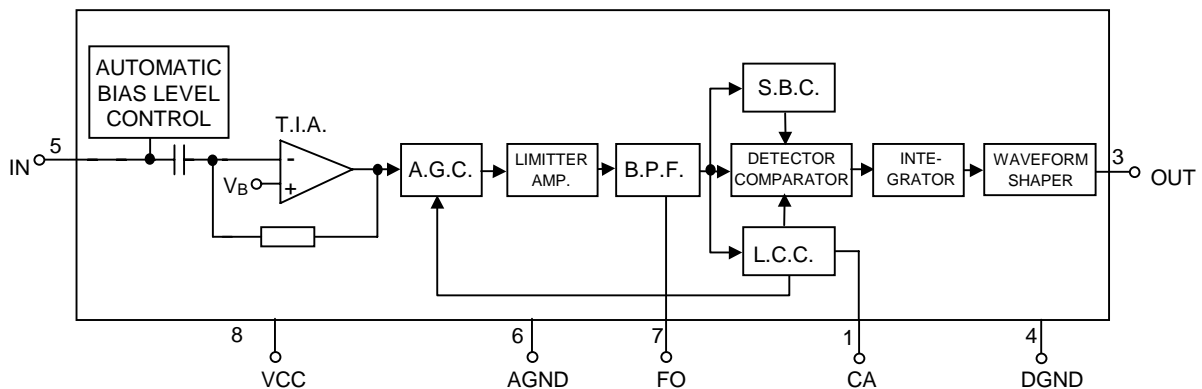



### PIN DESCRIPTIONS

PIN 1: CA - LCC capacitor connection pin.  
PIN 2: NC - No Connection.  
PIN 3: OUT - Output pin.  
PIN 4: DGND - Digital ground.

PIN 5: IN - Input pin (photodiode connection pin).  
PIN 6: AGND - Analog ground.  
PIN 7: FO - Band pass filter center frequency setting pin.  
PIN 8: VCC - Power supply pin.

### TYPICAL PERFORMANCE CHARACTERISTICS

Quiescent Current vs. Supply Voltage

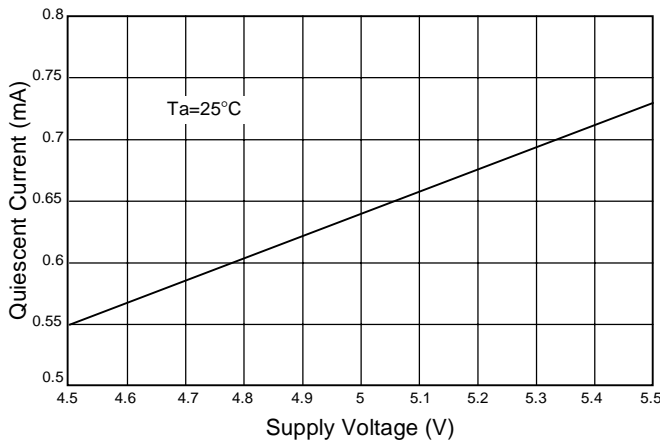

Supply Current vs. Temperature

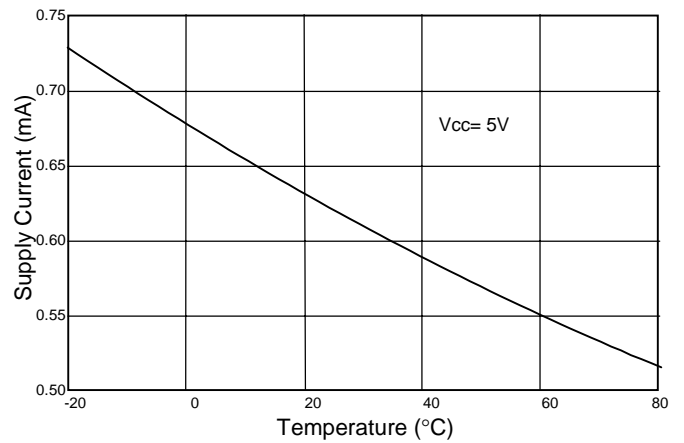

Voltage Gain vs. Input Signal Frequency

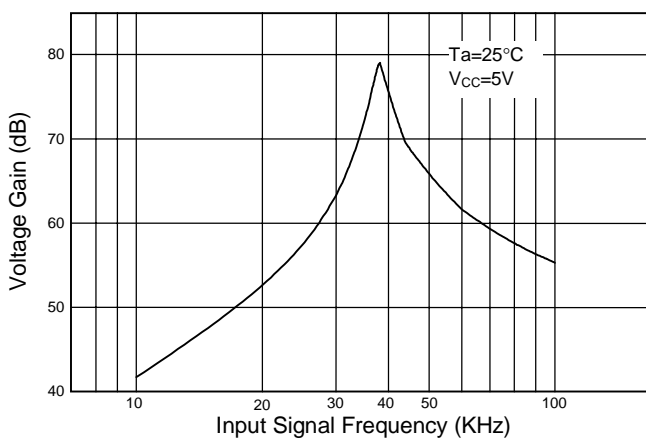

Center Frequency vs. Externally Attached Resistance to Pin 7

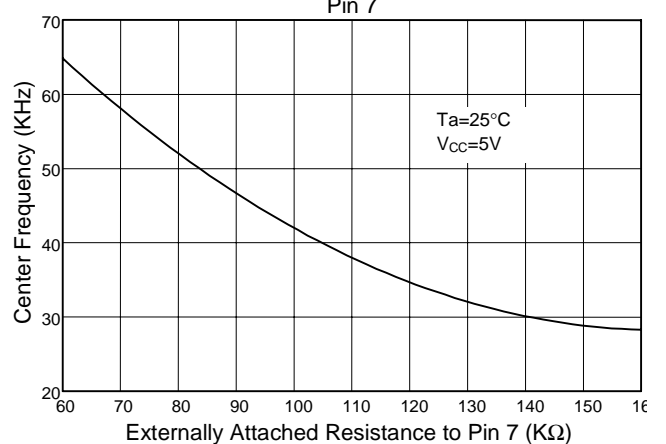



## ■ TYPICAL PERFORMANCE CHARACTERISTICS (Continued)

Pin 5 DC Voltage vs. Input DC Current

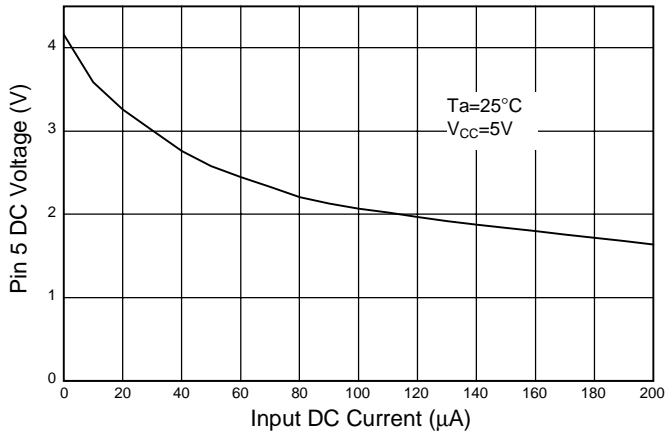

## ■ APPLICATION INFORMATIONS

### ● THE OPERATION

#### AUTOMATIC BIAS LEVEL CONTROL

An ABLC (Automatic Bias Level Control) circuit is built into the input section to prevent the input level from being saturated by the external disturbing lights, such that this circuit is actuated by a strong external disturbing light to fix the bias level of the input terminal.

#### TRANS-IMPEDANCE AMPLIFIER (T.I.A.)

The Trans-impedance amplifier is an inverted amplifier with a sufficiently low input resistance, which amplifies the input photocurrent pulses. The resistance of the input at the signal frequency should not be too high. Otherwise the wanted signal would be lost to the junction capacitance of photodiode.

#### AUTO-GAIN CONTROL AMPLIFIER (A.G.C.)

The voltage gain of auto-gain control amplifier is controlled by the voltage at CA pin. In so doing, it supports the long-time interference suppression of the evaluation circuit.

#### EVALUATION CIRCUIT

The signal delivered from the band-pass filter is compared with a reference by the detector comparator. This reference is determined by the short-time boost circuit and the long-time control circuit. The inherent offset of the detector comparator and the reference determine the sensitivity of the evaluation circuit. The

integrator is controlled by the above mentioned comparison. Its output is used to control the output stage after being processed through a schmitt-trigger. Use of the integrator keeps the output free of short-time interference. The ground of the evaluation circuit is routed out separately at pin 4, in order to minimize effect of the output switching edges.

#### SHORT-TIME BOOST CIRCUIT (S.B.C.)

The short-time boost circuit reduces the sensitivity of the evaluation circuit after reception of a signal. This prevents short-time interference from affecting the output. The reduction in sensitivity is achieved by boosting the reference input of the detector comparator.

#### LONG-TIME CONTROL CIRCUIT (L.C.C.)

The long-time control circuit improves the circuit's resistance to long-time interference by adapting the sensitivity of the evaluation circuit and the amplification of the AGC amplifier. Reduction of the evaluation circuit sensitivity is thereby achieved in the same way, as for the SBC, by raising the reference input of the detector comparator. The external capacitor C1 is charged as long as the signal is delivered from band pass filter and the voltage of C1 provides the necessary control voltage for AGC amplifier.



### ● DESIGN GUIDE

#### SETTING THE CENTER FREQUENCY OF BAND PASS FILTER

Connect a resistor from pin 7 to VCC to set the center frequency of band pass filter. The center frequency will be lower if the resistor value is higher. The relationships between center frequency of band pass filter and the resistance of external resistor are tabulated as below:

$f_0$ (KHz)	33	36	37	38	40	56.8
R1(K $\Omega$ )	130	118	114	110	104	72

#### SETTING LCC CAPACITOR C1

With the transmitted data signal with duty cycle lower than 0.4 (average, during the whole transmission),

the detection sensitivity is unchanged all the time. Otherwise, with the transmitted data signal with duty cycle higher than 0.4, the detection sensitivity will maintain unchanged for a proportional time period and gradually be reduced due to increasing control voltage at CA pin. Higher duty cycle enables more reduction of detection sensitivity in specific transmission time. Increasing the capacitance of C1 causes longer transmission time as duty cycle higher than the maximum allowable duty cycle.

#### GROUNDING

The AGND pin, DGND pin and all the external parts are recommended to be connected as much as possible to "one ground point" for good noise performance.

## ■ PHYSICAL DIMENSIONS

### ● 8 LEAD PLASTIC SO (unit: mm)

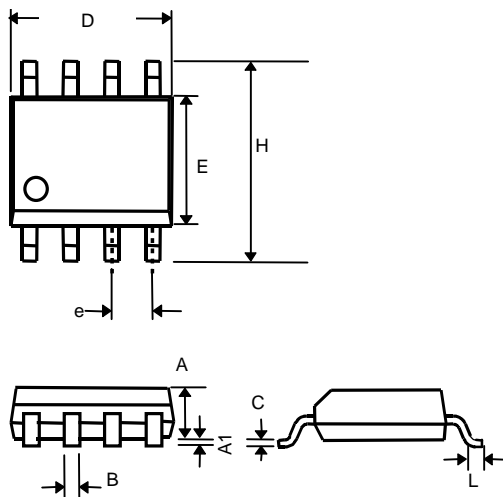

SYMBOL	MIN	MAX
A	1.35	1.75
A1	0.10	0.25
B	0.33	0.51
C	0.19	0.25
D	4.80	5.00
E	3.80	4.00
e	1.27(TYP)	
H	5.80	6.20
L	0.40	1.27



■ DIE DIMENSION

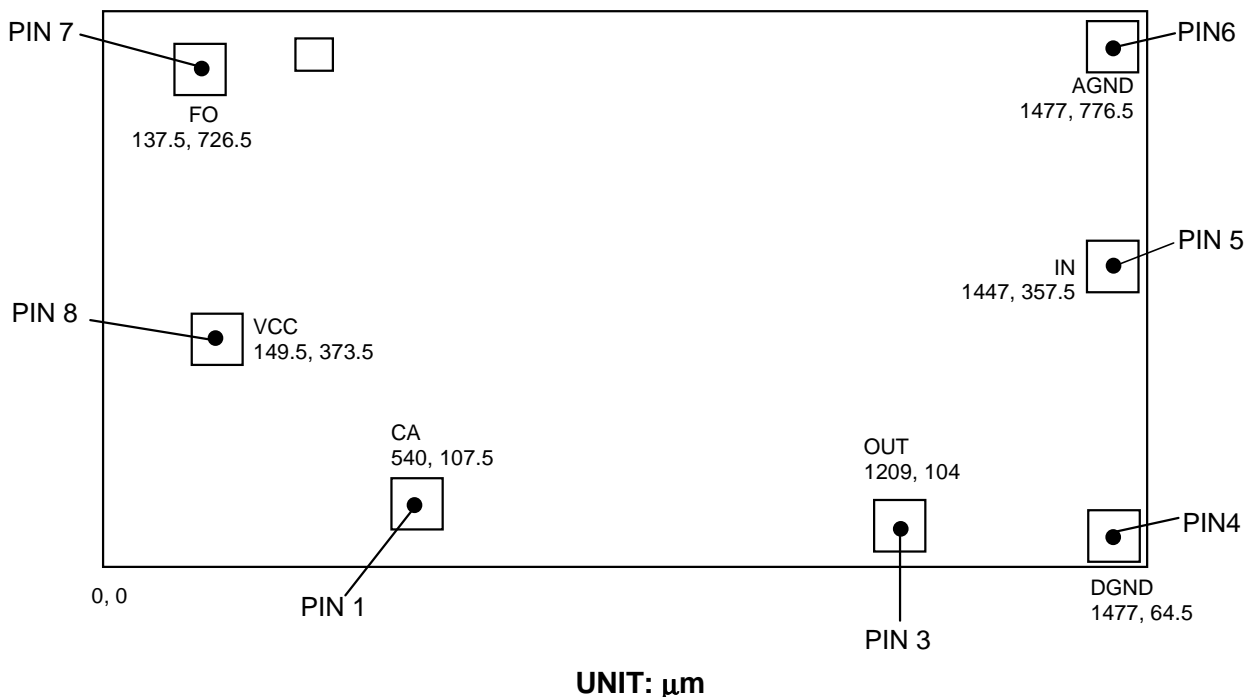

DIE SIZE: 1535 × 845  $\mu\text{m}^2$   
PAD SIZE: 100 × 100  $\mu\text{m}^2$   
DIE THICKNESS: 15 ± 1.5 mil