



FEATURES

- Reduction in Board Size due to Miniature Package SOT-23-5 and Less External Components.
- Ultra-Low Quiescent Current at $7\mu\text{A}$ ($V_{CC}=3.5\text{V}$).
- Ultra-Low Power-Down Current at $0.4\mu\text{A}$ ($V_{CC}=2.3\text{V}$).
- Precision Overcharge Protection Voltage
 - $4.35\text{V} \pm 50\text{mV}$ for the AIC1811A
 - $4.30\text{V} \pm 50\text{mV}$ for the AIC1811B
 - $4.25\text{V} \pm 50\text{mV}$ for the AIC1811C
- Built-in Delay Time Circuits for Overcharge, Over-discharge, and Overcurrent Protection.
- Load Detection Function during Overcharge Mode.
- Two Detection Levels for Overcurrent Protection.

APPLICATIONS

- Protection IC for One-Cell Lithium-Ion Battery Pack.

DESCRIPTION

The AIC1811 battery protection IC is designed to protect lithium-ion battery from damage or degrading the lifetime due to overcharge, overdischarge, and/or overcurrent for one-cell lithium-ion battery powered systems, such as cellular phones. The ultra-small package and less required external components make it ideal to integrate the AIC1811 into the limited space of battery pack.

The accurate $\pm 50\text{mV}$ overcharging detection voltage ensures safe and full utilization charging. Three different specification values for overcharge protection voltage are provided for various protection requirements. The very low standby current drains little current from the cell while in storage.

TYPICAL APPLICATION CIRCUIT

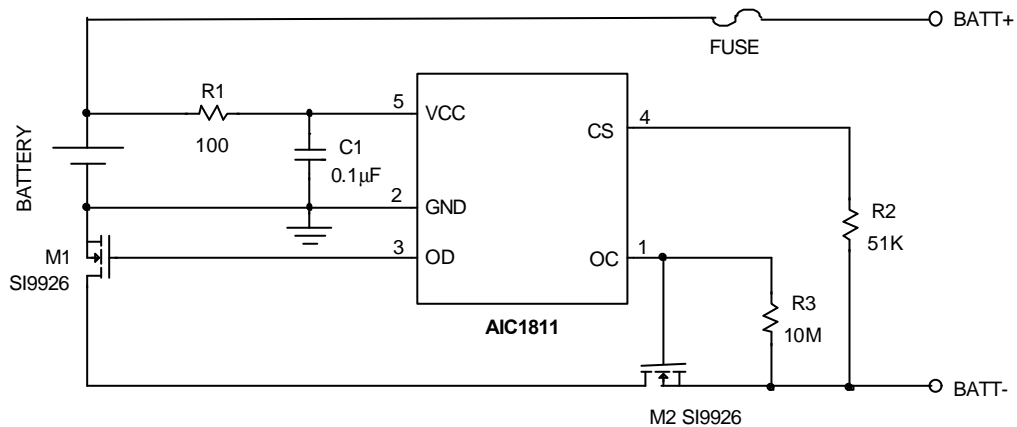

Protection Circuit for One-Cell Lithium-Ion Battery



ORDERING INFORMATION

AIC1811 XCX

- PACKAGE TYPE
V: SOT-23-5
- OVERCHARGE PROTECTION
A: 4.35V
B: 4.30V
C: 4.25V

ORDER NUMBER	PIN CONFIGURATION
AIC1811ACV AIC1811BCV AIC1811CCV (SOT-23-5)	TOP VIEW

ABSOLUTE MAXIMUM RATINGS

Supply Voltage 18V
 DC Voltage Applied on other Pins 18V
 Operating Temperature Range -40°C~85°C
 Storage Temperature Range - 65°C~125°C

TEST CIRCUIT

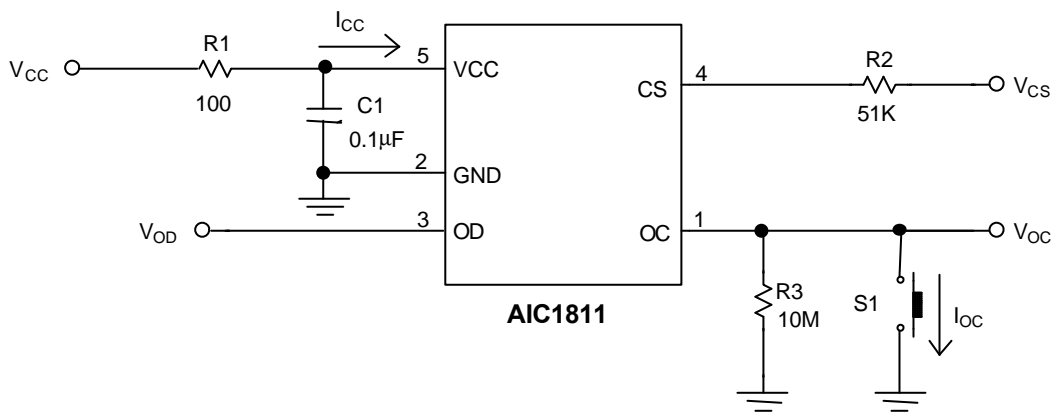

**ELECTRICAL CHARACTERISTICS** (Ta=25°C, unless otherwise specified.)

PARAMETER	TEST CONDITIONS	SYMBOL	MIN.	TYP.	MAX.	UNIT
Supply Current	V _{CC} =3.5V	I _{CC}		7	11	μA
Power-Down Current	V _{CC} =2.3V,	I _{PD}		0.4	1.0	μA
Overcharge Protection Voltage	AIC1811A	V _{OCP}	4.30	4.35	4.40	V
	AIC1811B		4.25	4.30	4.35	
	AIC1811C		4.20	4.25	4.30	
Overcharge Hysteresis Voltage		V _{HYS}	150	200	250	mV
Overdischarge Protection Voltage		V _{ODP}	2.2	2.4	2.6	V
Overdischarge Release Voltage		V _{ODR}	2.6	2.9	3.2	V
Overcurrent Protection Voltage	V _{CC} =3.5V	V _{OIP}	180	200	220	mV
Overcharge Delay Time	V _{CC} =V _{OCP} -0.1→ V _{OCP} + 0.1V	T _{OC}	50	100	150	mS
Overdischarge Delay Time	V _{CC} = 2.5V →2.3V	T _{OD}	50	100	150	mS
Overcurrent Delay Time (1)	V _{CC} =3.5V, 1V>V _{CS} >0.2V	T _{O11}	5	10	15	mS
Overcurrent Delay Time (2)	V _{CC} =3.5V, V _{CS} >1V	T _{O12}	150	300	450	μS
OC Pin Source Current	V _{CC} =3.5V, OC pin short to GND	I _{OC}	240	340	440	μA
OD Pin Output "H" Voltage		V _{DH}	V _{CC} -0.1	V _{CC} -0.02		V
OD Pin Output "L" Voltage		V _{DL}		0.01	0.1	V
Load Detection Threshold Voltage	V _{CC} =V _{OCP} -50mV	V _{LD}		0.3	0.4	V
Charge Detection Threshold Voltage	V _{CC} =2.3V	V _{CH}	-0.45	-0.3		V



BLOCK DIAGRAM

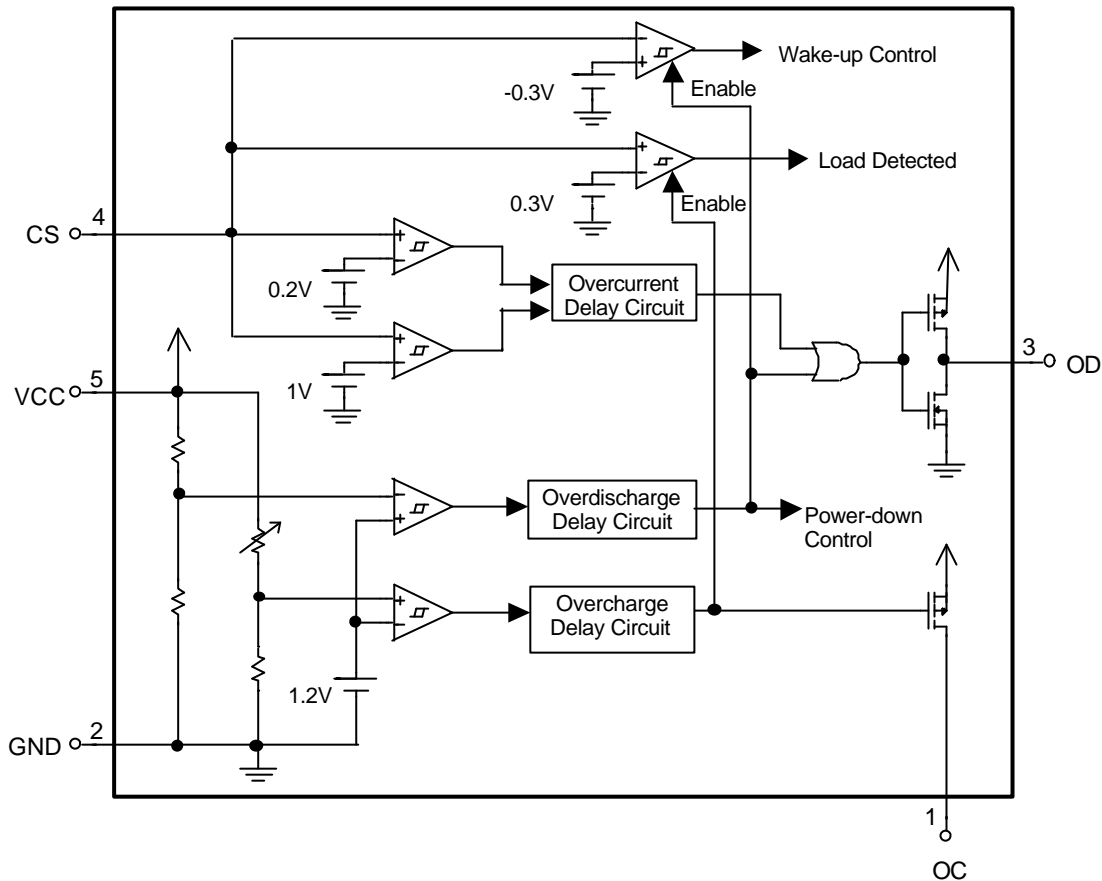

PIN DESCRIPTIONS

- PIN 1: OC** - PMOS open drain output for control of the charge control MOSFET M2. In normal mode, this PMOS turns on to pull the gate of the MOSFET M2 to high, then the MOSFET M2 turns on. When overcharge occurs, this PMOS turns off, then no current flows through R3 and the MOSFET M2 turns off.
- PIN 2: GND** - Ground pin. This pin is to be connected to the negative terminal of the battery cell.
- PIN 3: OD** - Output pin for control of the discharge control MOSFET M1. When overdischarge occurs, this pin

goes low to turn off the MOSFET M1 and discharging is inhibited.

- PIN 4: CS** - Input pin for current sensing. Using the sum of drain-source voltages of the MOSFET M1 and the MOSFET M2 (voltage between CS and GND), it senses discharge current during normal mode and detects whether charge current is present during power-down mode. It also used to detect whether load is connected during overcharge mode.

- PIN 5: VCC** - Power supply pin. This pin is to be connected to the positive terminal of the battery cell.



APPLICATION INFORMATIONS

THE OPERATION

Overcharge Protection

When the voltage of the battery cell exceeds the overcharge protection voltage (V_{OCP}) beyond the overcharge delay time (T_{OC}) period, charging is inhibited by the turning-off of the charge control MOSFET M2. The overcharge delay time is fixed to 100mS by IC internal circuit. The overcharge condition is released in two cases:

1. The voltage of the battery cell becomes lower than the overcharge release voltage (V_{OCR} or $V_{OCP} - V_{HYS}$) through self-discharge.
2. The voltage of the battery cell falls below the overcharge protection voltage (V_{OCP}) and a load is connected.

When the battery voltage is above V_{OCP} , the overcharge condition is never released even a load is connected to the pack.

Overdischarge Protection

When the voltage of the battery cell goes below the overdischarge protection voltage (V_{ODP}) beyond the overdischarge delay time (T_{OD}) period, discharging is inhibited by the turning-off of the discharge control MOSFET M1. The overdischarge delay time defaults to 100mS. Inhibition of discharging is immediately released when the voltage of the battery cell becomes higher than overdischarge release voltage (V_{ODR}) through charging.

Overcurrent Protection

In normal mode, the AIC1811 continuously monitors the discharge current by sensing the voltage of CS pin. If the voltage of CS pin exceeds the overcurrent protection voltage (V_{OIP}) beyond the overcurrent delay time (T_{OI}) period, the overcurrent protection circuit operates and discharging is inhibited by the turning-off of the discharge control MOSFET M1. The overcurrent condition returns to the normal mode when the load is released and the impedance between the BATT+ and BATT- terminals is 20M Ω or higher.

The AIC1811 is provided with the two overcurrent detection levels (0.2V and 1V) and the two overcurrent delay time (T_{OI1} and T_{OI2}) corresponding to each overcurrent detection level.

Load Detection after Overcharge

The load detection function after overcharge is implemented by detecting the CS pin voltage. Once a load is connected to the battery pack after overcharge, discharge current flows through the parasitic diode of MOSFET M2 and there is a diode

voltage drop between CS and GND. Load is determined to be connected to the pack if the CS pin voltage is above load detection threshold voltage (V_{LD}).

Power-Down after Overdischarge

When overdischarge occurs, the AIC1811 will go into power-down mode, turning off all the timing generation and detection circuitry to reduce the quiescent current to 0.4 μ A ($V_{CC}=2.3V$). At the same time, the CS pin is pull-high to VCC through a high resistance resistor.

Charge Detection after Overdischarge

When overdischarge occurs, the discharge control MOSFET M1 turns off and discharging is inhibited. However, charging is still permitted through the parasitic diode of M1. Once the charger is connected to the battery pack, the AIC1811 immediately turns on all the timing generation and detection circuitry. Charging is determined to be in progress if the voltage between CS and GND is below charge detection threshold voltage (V_{CH}).

DESIGN GUIDE

Selection of External Control MOSFETs

Because the overcurrent protection voltage is preset, the threshold current for overcurrent detection is determined by the turn-on resistance of the discharge control MOSFET M1. The turn-on resistance of the external control MOSFETs can be determined by the equation: $R_{ON} = V_{OIP} / (2 \times I_T)$ (I_T is the overcurrent threshold current). For example, if the overcurrent threshold current I_T is designed to be 3A, the turn-on resistance of the external control MOSFETs must be 33m Ω . Users should be aware that turn-on resistance of the MOSFET changes with temperature variation due to heat dissipation. It changes with the voltage between gate and source as well. (Turn-on resistance of a MOSFET increases as the voltage between gate and source decreases). Once the turn-on resistance of the external MOSFET changes, the overcurrent threshold current will change accordingly.

Suppressing the Ripple and Disturbance from Charger

To suppress the ripple and disturbance from charger, connecting R1, C1 to VCC pin is recommended.

Protection at CS pin

R2 is used for latch-up protection when charger is



connected under overdischarge condition and overstress protection at reverse connecting of a charger. Larger value of R2 reduces the charger leakage current in overcharge mode, but possibly disables the charge detection function after

overdischarge. Resistance of 51KΩ is recommended.

TIMING DIAGRAM

Overcharge and Overdischarge Protection

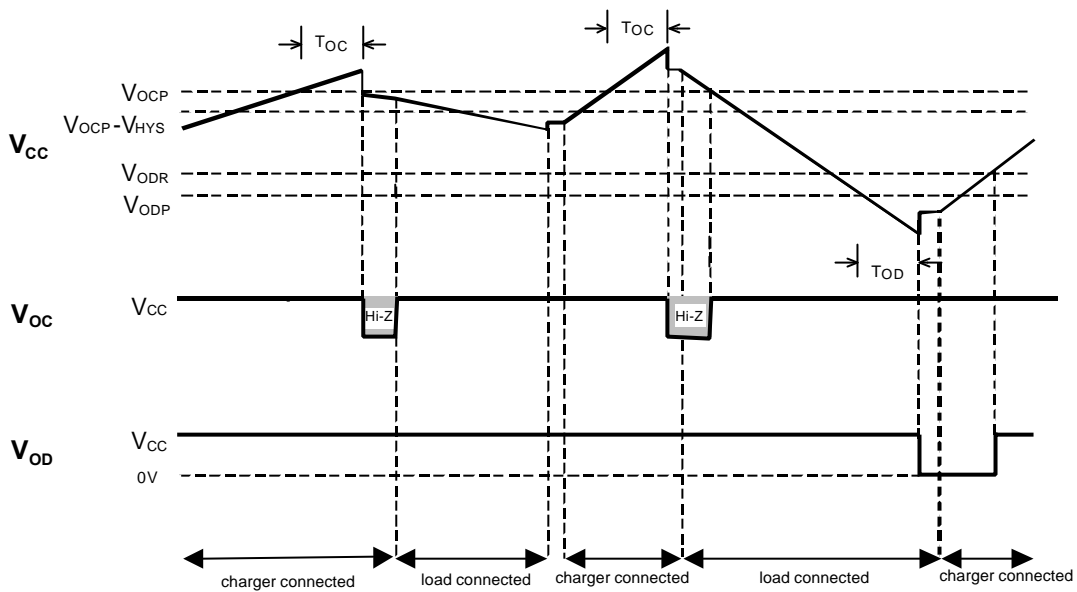

Overcurrent Protection ($V_{CC}=3.5V$)

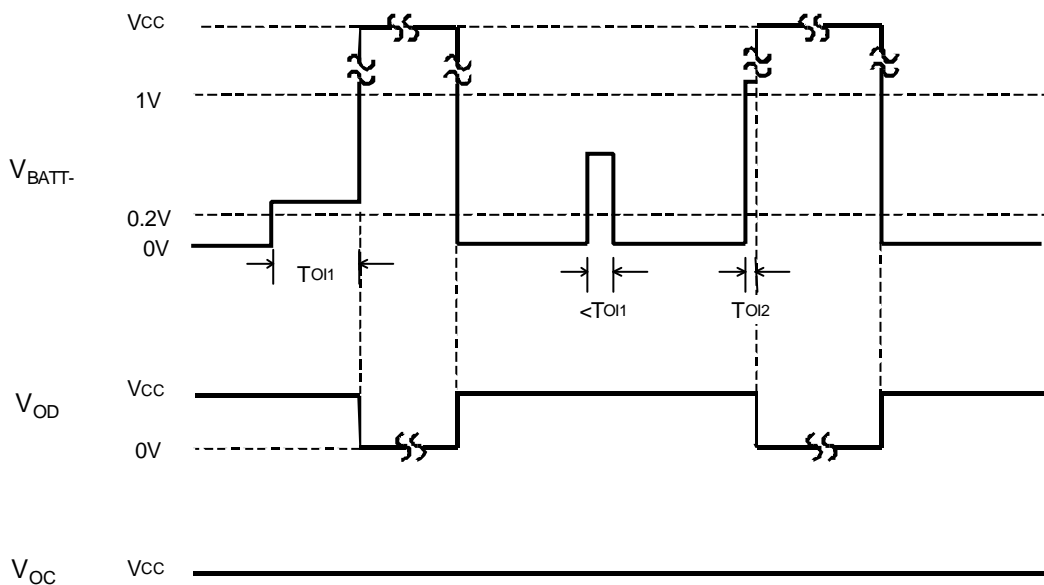



PHYSICAL DIMENSIONS

● SOT-25 (unit: mm)

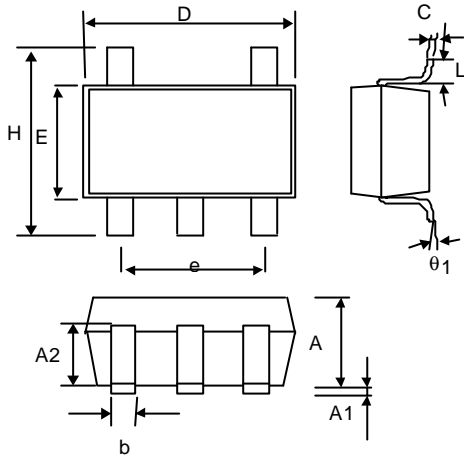

SYMBOL	MIN	MAX
A	1.00	1.30
A1	—	0.10
A2	0.70	0.90
b	0.35	0.50
C	0.10	0.25
D	2.70	3.10
E	1.40	1.80
e	1.90 (TYP)	
H	2.60	3.00
L	0.37	—
θ1	1°	9°

● SOT-23-5 MARKING

Part No.	Marking
AIC1811ACV	EA0A
AIC1811BCV	EA0B
AIC1811CCV	EA0C