



FEATURES

- Low Dropout Voltage of 750mV at 500mA Output Current (5.0V Output Version).
- Guaranteed 500mA Output Current.
- Internal 1.5Ω P-MOSFET Draws no Base Current.
- Low Ground Current at 65μA.
- 2% Accuracy Output Voltage of 3.3V/ 3.5V/ 3.7V/ 3.8V/ 5.0V/ 5.2V.
- Input Voltage Range up to 12V (5.0V Output Version).
- Needs only 4.7μF for Stability.
- Current and Thermal Limiting.

APPLICATIONS

- Voltage Regulator for CD-ROM Drivers.
- Voltage Regulator for LAN Cards.
- Voltage Regulator for Monitor Microprocessor.
- Voltage Regulator for RAM Module.
- Wireless Communication Systems.
- Battery Powered Systems.

DESCRIPTION

The AIC1723 is a 3-pin low dropout linear regulator. The superior characteristics of the AIC1723 include zero base current loss, very low dropout voltage, and 2% accuracy output voltage. Typical ground current remains approximately 65μA, from no load to maximum loading conditions. Dropout voltage at 500mA output current is exceptionally low: 750mV for the AIC1723-50 and AIC1723-52, 900mV for the AIC1723-38, AIC1723-37, AIC1723-35, and the AIC1723-33. Output current limiting and thermal limiting are built in to provide maximal protection to the AIC1723 against fault conditions.

The AIC1723 comes in the popular SOT-223, TO-251 and TO-252 packages.

TYPICAL APPLICATION CIRCUIT

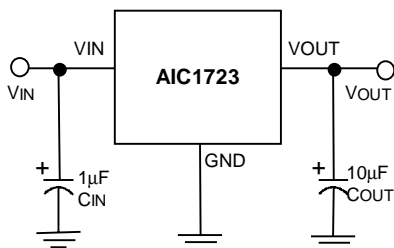

Low Dropout Linear Regulator



ORDERING INFORMATION

AIC1723-XXXX

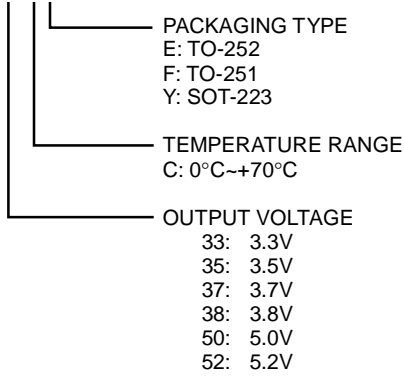

ORDER NUMBER	PIN CONFIGURATION	
AIC1723-33CE AIC1722-35CE AIC1722-37CE AIC1722-38CE AIC1722-50CE AIC1722-52CE (TO-252)	FRONT VIEW 1: VOUT 2: GND 3: VIN	
AIC1723-33CF AIC1722-35CF AIC1722-37CF AIC1722-38CF AIC1722-50CF AIC1722-52CF (TO-251)	FRONT VIEW 1: VOUT 2: GND 3: VIN	
AIC1723-33CY AIC1722-35CY AIC1722-37CY AIC1722-38CY AIC1722-50CY AIC1722-52CY (SOT-223)	FRONT VIEW 1: VOUT 2: GND 3: VIN	

ABSOLUTE MAXIMUM RATINGS

Input Supply Voltage	-0.3~12V
Operating Junction Temperature Range	-40°C~ 125°C
Storage Temperature Range	-65°C~150°C
Power Dissipation	0.85W
Thermal Resistance θ_{JC}	TO-251, TO-252 Package	12.5°C/W
	SOT-223 Package	15°C/W

TEST CIRCUIT

Refer to the TYPICAL APPLICATION CIRCUIT

ELECTRICAL CHARACTERISTICS ($T_a=25^\circ\text{C}$, $C_{IN}=1\mu\text{F}$, $C_{OUT}=10\mu\text{F}$, unless otherwise specified.)

PARAMETER	TEST CONDITIONS		MIN.	TYP.	MAX.	UNIT
Output Voltage	No Load					V
	AIC1723-52	$V_{IN}=5.5\sim 12V$	5.100	5.2	5.300	
	AIC1723-50	$V_{IN}=5.5\sim 12V$	4.900	5.0	5.100	
	AIC1723-38	$V_{IN}=4.7\sim 12V$	3.725	3.8	3.875	
	AIC1723-37	$V_{IN}=4.7\sim 12V$	3.625	3.7	3.775	
	AIC1723-35	$V_{IN}=4.7\sim 12V$	3.430	3.5	3.570	
	AIC1723-33	$V_{IN}=3.6\sim 12V$	3.234	3.3	3.366	

**ELECTRICAL CHARACTERISTICS (Continued)**

PARAMETER	TEST CONDITIONS		MIN.	TYP.	MAX.	UNIT
Output Voltage Temperature Coefficient	(Note 1)			50		PPM/°C
Line Regulation	$I_L=1\text{mA}$					
	AIC1723-52	$V_{IN}=5.5\sim 12\text{V}$		3	10	mV
	AIC1723-50	$V_{IN}=5.5\sim 12\text{V}$		3	10	
	AIC1723-38	$V_{IN}=4.7\sim 12\text{V}$		3	10	
	AIC1723-37	$V_{IN}=4.7\sim 12\text{V}$		3	10	
	AIC1723-35	$V_{IN}=4.7\sim 12\text{V}$		3	10	
	AIC1723-33	$V_{IN}=4.7\sim 12\text{V}$		3	10	
Load Regulation (Note 2)						
	AIC1723-52	$V_{IN}=7\text{V}, I_L=0.1\sim 500\text{mA}$		20	50	mV
	AIC1723-50	$V_{IN}=7\text{V}, I_L=0.1\sim 500\text{mA}$		20	50	
	AIC1723-38	$V_{IN}=5\text{V}, I_L=0.1\sim 500\text{mA}$		20	50	
	AIC1723-37	$V_{IN}=5\text{V}, I_L=0.1\sim 500\text{mA}$		20	50	
	AIC1723-35	$V_{IN}=5\text{V}, I_L=0.1\sim 500\text{mA}$		20	50	
	AIC1723-33	$V_{IN}=5\text{V}, I_L=0.1\sim 500\text{mA}$		20	50	
Current Limit (Note 3)						
	AIC1723-52	$V_{IN}=7\text{V}, V_{OUT}=0\text{V}$		650		mA
	AIC1723-50	$V_{IN}=7\text{V}, V_{OUT}=0\text{V}$		650		
	AIC1723-38	$V_{IN}=5\text{V}, V_{OUT}=0\text{V}$		650		
	AIC1723-37	$V_{IN}=5\text{V}, V_{OUT}=0\text{V}$		650		
	AIC1723-35	$V_{IN}=5\text{V}, V_{OUT}=0\text{V}$		650		
	AIC1723-33	$V_{IN}=5\text{V}, V_{OUT}=0\text{V}$		650		
Dropout Voltage (Note 4)						
	AIC1723s	$I_L=0.1\text{mA}$		0.2	10	mV
	AIC1723-52	$I_L=500\text{mA}$		750	850	
	AIC1723-50	$I_L=500\text{mA}$		750	850	
	AIC1723-38	$I_L=500\text{mA}$		900	1050	
	AIC1723-37	$I_L=500\text{mA}$		900	1050	
	AIC1723-35	$I_L=500\text{mA}$		900	1050	
	AIC1723-33	$I_L=500\text{mA}$		900	1050	
Ground Current	$I_O=0.1\text{mA}\sim I_{MAX}$					
	AIC1723-52	$V_{IN}=5.5\sim 12\text{V}$		65	90	μA
	AIC1723-50	$V_{IN}=5.5\sim 12\text{V}$		65	90	
	AIC1723-38	$V_{IN}=4.7\sim 12\text{V}$		65	90	
	AIC1723-37	$V_{IN}=4.7\sim 12\text{V}$		65	90	
	AIC1723-35	$V_{IN}=4.7\sim 12\text{V}$		65	90	
	AIC1723-33	$V_{IN}=4\sim 12\text{V}$		65	90	

Note 1: Guaranteed by design.

Note 2: Regulation is measured at constant junction temperature, using pulse testing with a low ON time.

Note 3: Current limit is measured by pulsing a short time.

Note 4: Dropout voltage is defined as the input to output differential at which the output voltage drops 100mV below the value measured with a 1V differential.



TYPICAL PERFORMANCE CHARACTERISTICS

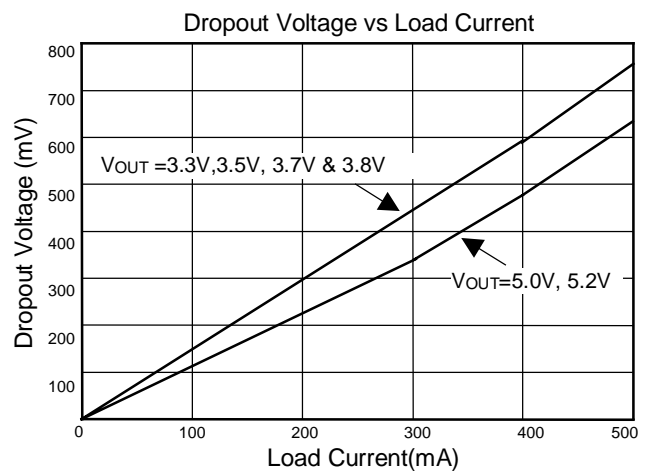
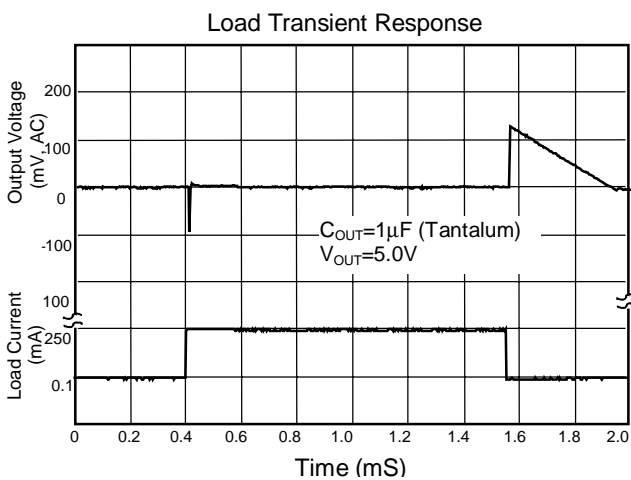
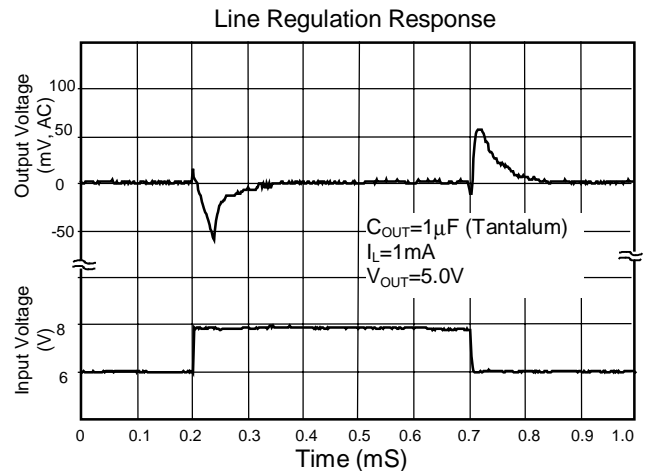
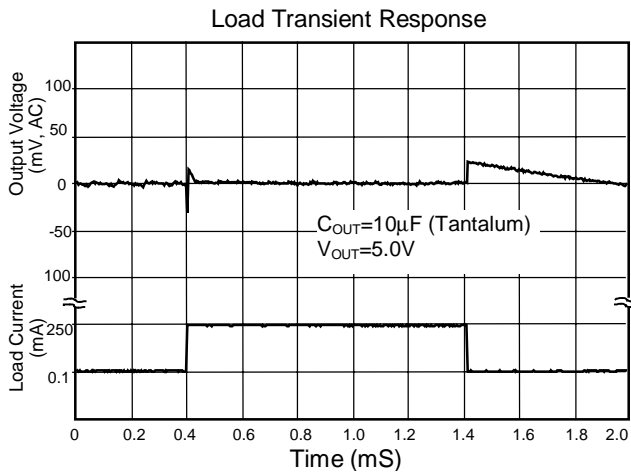
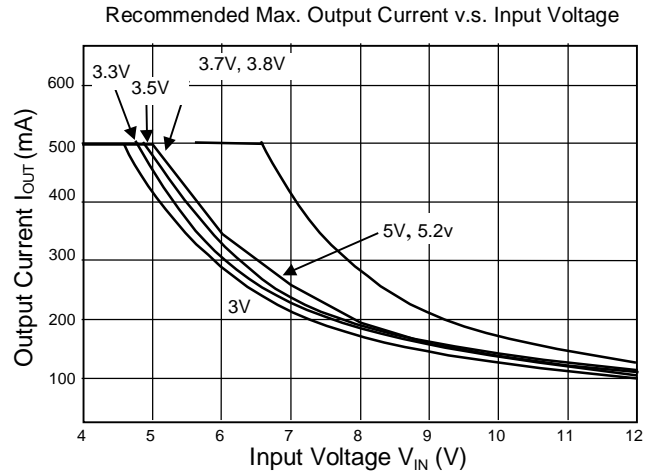
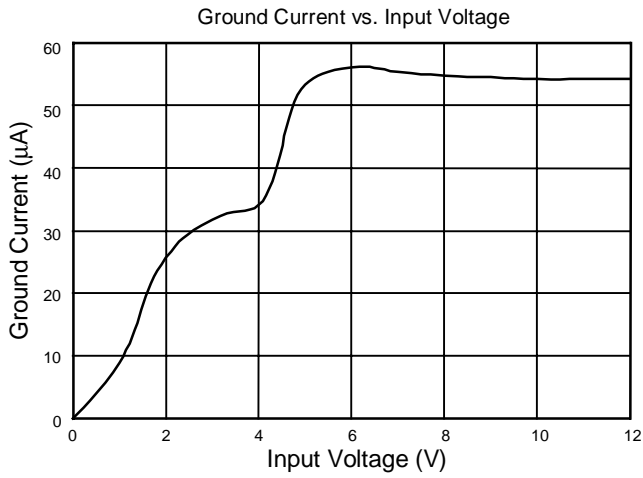



■ BLOCK DIAGRAM

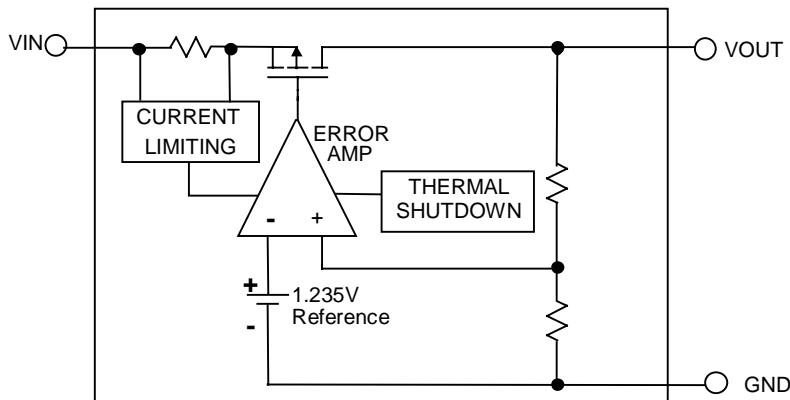

■ PIN DESCRIPTION

VOUT PIN - Output pin.

GND PIN - Power GND.

VIN PIN - Power Supply Input.

■ APPLICATION INFORMATIONS

A 4.7 μ F (or greater) capacitor is required between the AIC1723 output and ground for stability. Without this capacitor the part will oscillate. Even though most types of capacitor may work, the equivalent series resistance (ESR) should be held to 5 Ω or less if Aluminum electrolytic type is used. Many Aluminum electrolytics have electrolytes that freeze at about -30°C, so solid tantalums are

recommended for operation below -25°C. The value of this capacitor may be increased without limit.

A 0.1 μ F capacitor (or greater) should be placed from the AIC1723 input to ground if the lead inductance between the input and power source exceeds 500nH (approximately 10 inches of trace).



PHYSICAL DIMENSIONS

● TO-251

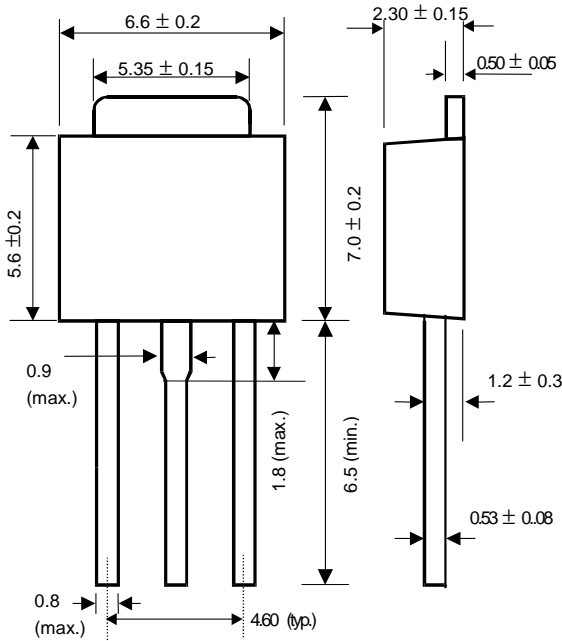

● TO-252

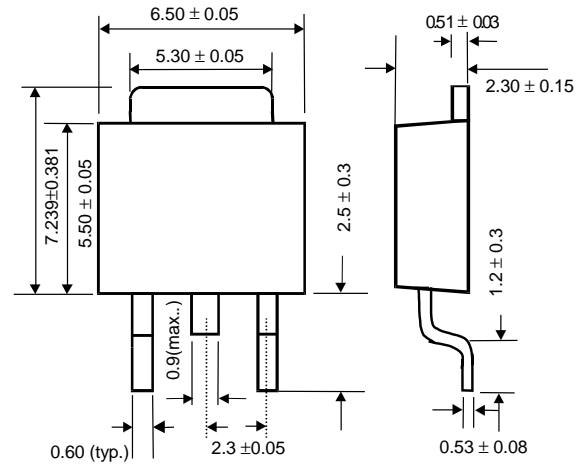

● SOT-223

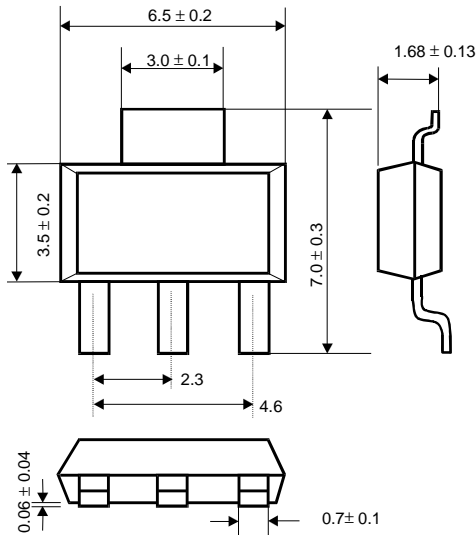

● SOT-223 MARKING

Part No.	Marking
AIC1723-33	AJ33
AIC1723-35	AJ35
AIC1723-37	AJ37
AIC1723-38	AJ38
AIC1723-50	AJ50
AIC1723-52	AJ52

UNIT: mm