



### FEATURES

- Low Dropout Voltage of 130mV at 100mA Output Current (5.2V Output Version).
- Guaranteed 300mA Output Current.
- Internal 1.3Ω P-MOSFET Draws no Base Current.
- Low Ground Current at 55μA.
- 2% Accuracy Output Voltage of 3.3V/ 3.5V/ 3.7V/ 3.8V/ 5.0V/ 5.2V.
- Input Voltage Range up to 12V.
- Needs only 1μF for Stability.
- Current and Thermal Limiting.

### APPLICATIONS

- Voltage Regulator for CD-ROM Drivers.
- Voltage Regulator for LAN Cards.
- Voltage Regulator for Microprocessor.
- Wireless Communication Systems.
- Battery Powered Systems.

### DESCRIPTION

The AIC1722 is a 3-pin low dropout linear regulator. The superior characteristics of the AIC1722 include zero base current loss, very low dropout voltage, and 2% accuracy output voltage. Typical ground current remains approximately 55 μA, from no load to maximum loading conditions. Dropout voltage at 100mA output current is exceptionally low: 130mV for the AIC1722-50 and AIC1722-52, 180mV for the AIC1722-33, AIC1722-35, and AIC1722-37 AIC1722-38. Output current limiting and thermal limiting are built in to provide maximal protection to the AIC1722 against fault conditions.

The AIC1722 comes in the popular 3-pin SOT-89 and TO-92 packages.

### TYPICAL APPLICATION CIRCUIT

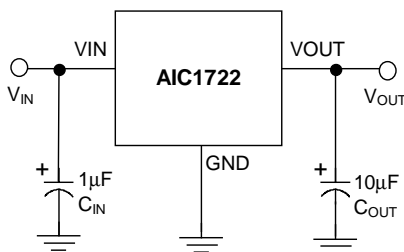

Low Dropout Linear Regulator



**ORDERING INFORMATION**

AIC1722-XXXXX

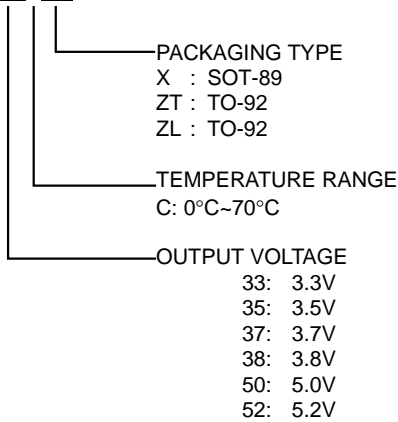

| ORDER NUMBER  | PIN CONFIGURATION                             |
|---|---|
| AIC1722-33CX<br>AIC1722-35CX<br>AIC1722-37CX<br>AIC1722-38CX<br>AIC1722-50CX<br>AIC1722-52CX (SOT-89)             | FRONT VIEW<br>1: VOUT<br>2: GND<br>3: VIN<br> |
| AIC1722-33CZT<br>AIC1722-35CZT<br>AIC1722-37CZT<br>AIC1722-38CZT<br>AIC1722-50CZT<br>AIC1722-52CZT (TO-92 T TYPE) | TOP VIEW<br>1: GND<br>2: VIN<br>3: VOUT<br>   |
| AIC1722-33CZL<br>AIC1722-35CZL<br>AIC1722-37CZL<br>AIC1722-38CZL<br>AIC1722-50CZL<br>AIC1722-52CZL (TO-92 L TYPE) | TOP VIEW<br>1: VIN<br>2: GND<br>3: VOUT<br>   |

**ABSOLUTE MAXIMUM RATINGS**

|  |   |
|--|---|
| Input Supply Voltage .....                 | -0.3~12V  |
| Operating Junction Temperature Range ..... | -40°C~ 125°C  |
| Storage Temperature Range .....            | -65°C~150°C   |
| Power Dissipation                          | SOT-89 Package ..... 0.5W<br>TO-92 Package ..... 0.5W |

**TEST CIRCUIT**

Refer to the TYPICAL APPLICATION CIRCUIT

**ELECTRICAL CHARACTERISTICS (Ta=25°C, CIN=1μF, COUT=10μF, unless otherwise specified.)**

| PARAMETER                               | TEST CONDITIONS          |                          | MIN.  | TYP.  | MAX.  | UNIT   |
|---|--------------------------|--------------------------|-------|-------|-------|--------|
| Output Voltage                          | No Load                  |                          |       |       |       | V      |
|   | AIC1722-52               | V <sub>IN</sub> =5.5~12V | 5.100 | 5.2   | 5.300 |        |
|   | AIC1722-50               | V <sub>IN</sub> =5.5~12V | 4.900 | 5.0   | 5.100 |        |
|   | AIC1722-38               | V <sub>IN</sub> =4.1~12V | 3.725 | 3.8   | 3.875 |        |
|   | AIC1722-37               | V <sub>IN</sub> =4.0~12V | 3.625 | 3.7   | 3.775 |        |
|   | AIC1722-35               | V <sub>IN</sub> =4.0~12V | 3.430 | 3.5   | 3.570 |        |
| AIC1722-33                              | V <sub>IN</sub> =3.6~12V | 3.235                    | 3.3   | 3.365 |       |        |
| Output Voltage Temperature Coefficiency | (Note 1)                 |                          |       | 50    | 150   | PPM/°C |

**ELECTRICAL CHARACTERISTICS (Continued)**

| PARAMETER                   | TEST CONDITIONS                | MIN.   | TYP.                                  | MAX. | UNIT          |
|-----------------------------|--------------------------------|--|---------------------------------------|------|---------------|
| Line Regulation             | $I_L=1\text{mA}$               |  |                                       |      |               |
|                             | AIC1722-52                     | $V_{IN}=5.5\sim 12\text{V}$                  | 3                                     | 10   | mV            |
|                             | AIC1722-50                     | $V_{IN}=5.5\sim 12\text{V}$                  | 3                                     | 10   |               |
|                             | AIC1722-38                     | $V_{IN}=4.1\sim 12\text{V}$                  | 3                                     | 10   |               |
|                             | AIC1722-37                     | $V_{IN}=4.0\sim 12\text{V}$                  | 3                                     | 10   |               |
|                             | AIC1722-35                     | $V_{IN}=4.0\sim 12\text{V}$                  | 3                                     | 10   |               |
|                             | AIC1722-33                     | $V_{IN}=3.6\sim 12\text{V}$                  | 3                                     | 10   |               |
| Load Regulation<br>(Note 2) | AIC1722-52                     | $V_{IN}=7\text{V}, I_L=0.1\sim 300\text{mA}$ | 7                                     | 25   | mV            |
|                             | AIC1722-50                     | $V_{IN}=7\text{V}, I_L=0.1\sim 300\text{mA}$ | 7                                     | 25   |               |
|                             | AIC1722-38                     | $V_{IN}=5\text{V}, I_L=0.1\sim 300\text{mA}$ | 7                                     | 25   |               |
|                             | AIC1722-37                     | $V_{IN}=5\text{V}, I_L=0.1\sim 300\text{mA}$ | 7                                     | 25   |               |
|                             | AIC1722-35                     | $V_{IN}=5\text{V}, I_L=0.1\sim 300\text{mA}$ | 7                                     | 25   |               |
|                             | AIC1722-33                     | $V_{IN}=5\text{V}, I_L=0.1\sim 300\text{mA}$ | 7                                     | 25   |               |
|                             | Current Limit<br>(Note 3)      | AIC1722-52                                   | $V_{IN}=7\text{V}, V_{OUT}=0\text{V}$ | 350  | 440           |
| AIC1722-50                  |                                | $V_{IN}=7\text{V}, V_{OUT}=0\text{V}$        | 350                                   | 440  |               |
| AIC1722-38                  |                                | $V_{IN}=7\text{V}, V_{OUT}=0\text{V}$        | 350                                   | 440  |               |
| AIC1722-37                  |                                | $V_{IN}=5\text{V}, V_{OUT}=0\text{V}$        | 350                                   | 440  |               |
| AIC1722-35                  |                                | $V_{IN}=5\text{V}, V_{OUT}=0\text{V}$        | 350                                   | 440  |               |
| AIC1722-33                  |                                | $V_{IN}=5\text{V}, V_{OUT}=0\text{V}$        | 350                                   | 440  |               |
| Dropout Voltage<br>(Note 4) |                                | AIC1722s                                     | $I_L=0.1\text{mA}$                    | 0.2  | 10            |
|                             | AIC1722-52                     | $I_L=300\text{mA}$                           | 400                                   | 500  |               |
|                             | AIC1722-50                     | $I_L=300\text{mA}$                           | 400                                   | 500  |               |
|                             | AIC1722-38                     | $I_L=300\text{mA}$                           | 540                                   | 640  |               |
|                             | AIC1722-37                     | $I_L=300\text{mA}$                           | 540                                   | 640  |               |
|                             | AIC1722-35                     | $I_L=300\text{mA}$                           | 540                                   | 640  |               |
|                             | AIC1722-33                     | $I_L=300\text{mA}$                           | 540                                   | 640  |               |
| Ground Current              | $I_O=0.1\text{mA}\sim I_{MAX}$ |  |                                       |      |               |
|                             | AIC1722-52                     | $V_{IN}=5.5\sim 12\text{V}$                  | 55                                    | 80   | $\mu\text{A}$ |
|                             | AIC1722-50                     | $V_{IN}=5.5\sim 12\text{V}$                  | 55                                    | 80   |               |
|                             | AIC1722-38                     | $V_{IN}=4\sim 12\text{V}$                    | 55                                    | 80   |               |
|                             | AIC1722-37                     | $V_{IN}=4\sim 12\text{V}$                    | 55                                    | 80   |               |
|                             | AIC1722-35                     | $V_{IN}=4\sim 12\text{V}$                    | 55                                    | 80   |               |
|                             | AIC1722-33                     | $V_{IN}=4\sim 12\text{V}$                    | 55                                    | 80   |               |

Note 1: Guaranteed by design.

Note 2: Regulation is measured at constant junction temperature, using pulse testing with a low ON time.

Note 3: Current limit is measured by pulsing a short time.

Note 4: Dropout voltage is defined as the input to output differential at which the output voltage drops 100mV below the value measured with a 1V differential.



### TYPICAL PERFORMANCE CHARACTERISTICS

Output Voltage vs. Temperature

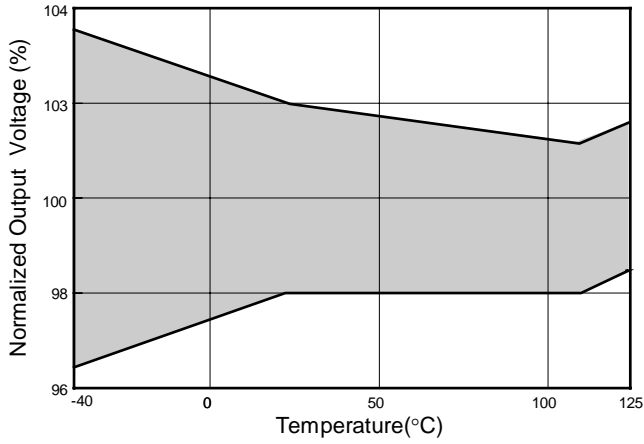

Ground Current vs. Input Voltage

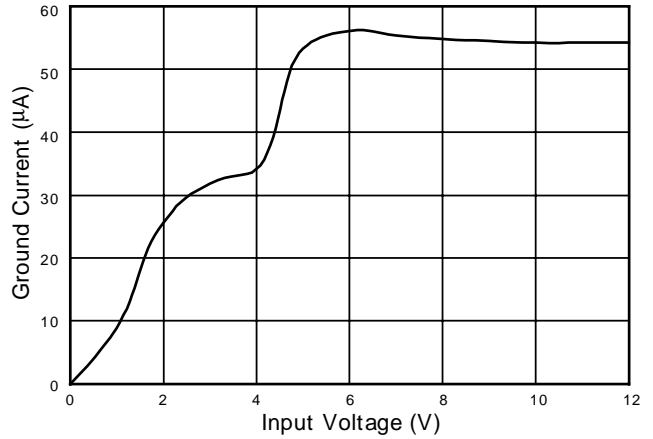

Ground Current vs. Temperature

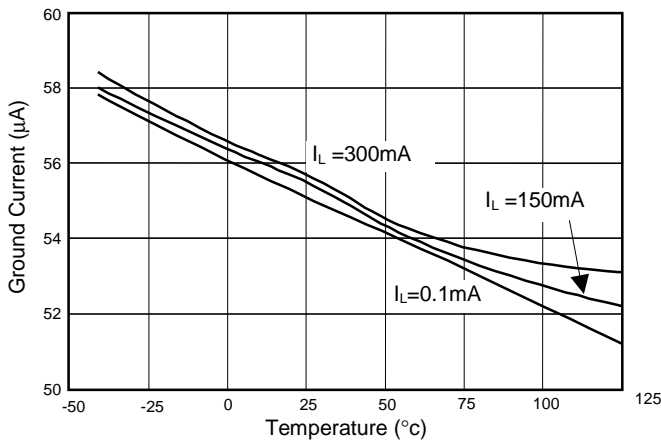

Dropout Voltage vs. Load Current

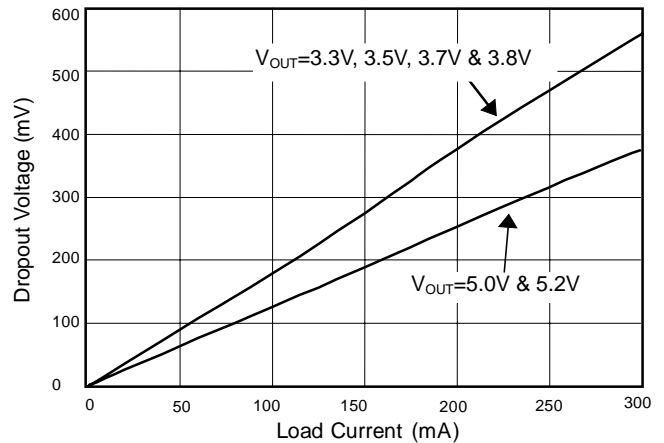

Line Transient Response

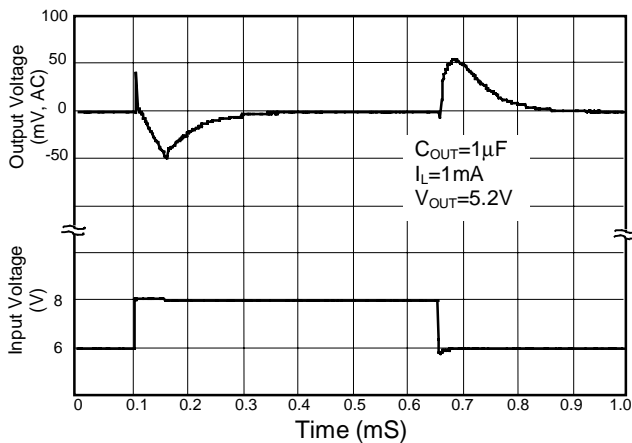

Load transient Response

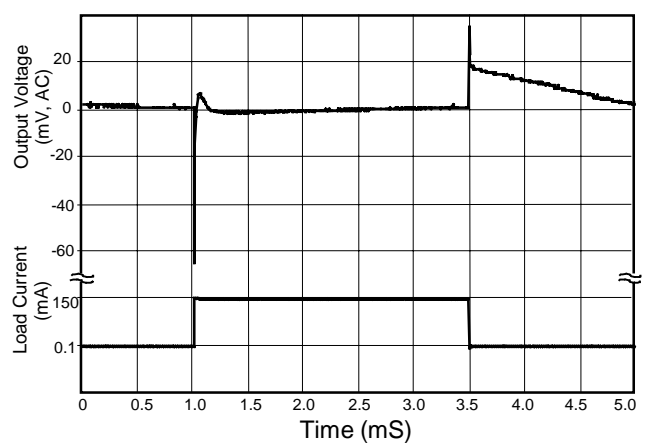



### TYPICAL PERFORMANCE CHARACTERISTICS (Continued)

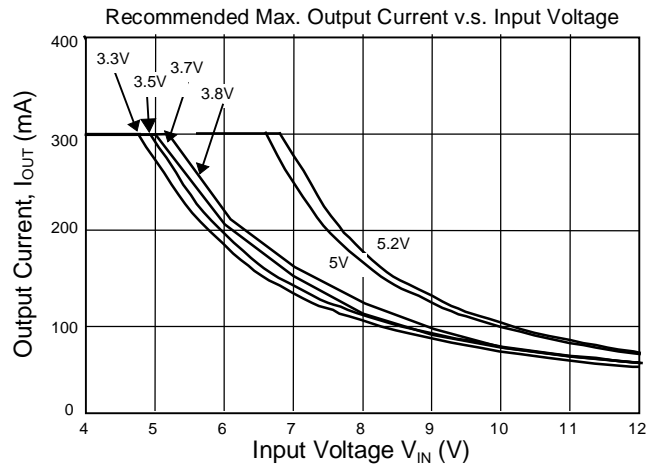
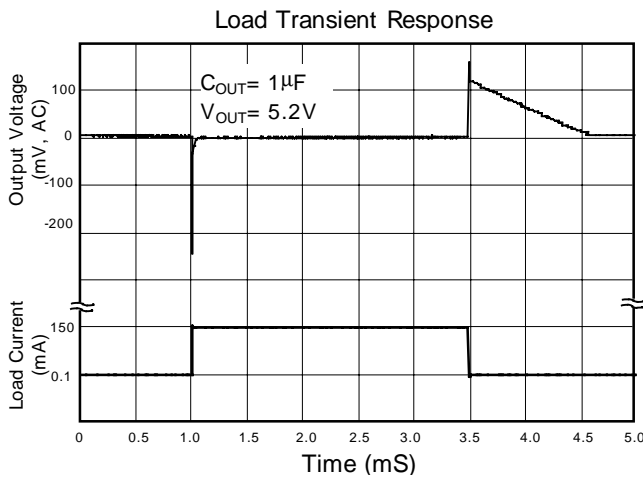

### BLOCK DIAGRAM

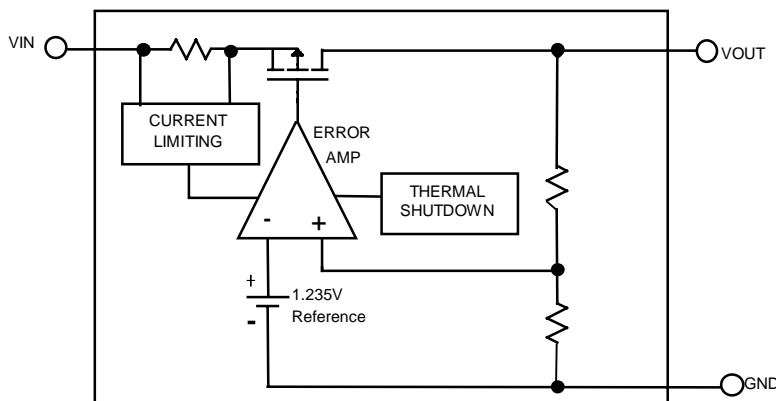

### PIN DESCRIPTION

- VOUT PIN - Output pin.
- GND PIN - Power GND.
- VIN PIN - Power Supply Input.

### APPLICATION INFORMATIONS

A  $1\mu F$  (or greater) capacitor is required between the AIC1722 output and ground for stability. Without this capacitor the part will oscillate. Even though most types of capacitor may work, the equivalent series resistance (ESR) should be held to  $5\Omega$  or less if Aluminum electrolytic type is used. Many Aluminum electrolytics have electrolytes that freeze at about  $-30^\circ C$ , so solid tantalums are recommended for

operation below  $-25^\circ C$ . The value of this capacitor may be increased without limit.

A  $0.1\mu F$  capacitor (or greater) should be placed from the AIC1722 input to ground if the lead inductance between the input and power source exceeds  $500nH$  (approximately 10 inches of trace).

