



## FEATURES

- Ultra-Low Quiescent Current.
- 1.5V to 10.0V Input Voltage Operation.
- Flexible Detection Voltage Setting  
0.1V Step in the Range of 1.6V to 6.0V
- High Detection Voltage Accuracy at  $\pm 2.5\%$ .
- Built-In Detection Voltage Hysteresis.
- Three Output Types: N-ch, P-ch and CMOS.
- Space Saving Packages: TO-92, SOT-89, SOT-23 and SOT23-5.

## FEATURES

- Battery Checker for Battery-Operated Systems.
- CPU & Logic Circuit Reset.
- Memory Back-up Circuit.
- Level Discriminator.
- Power Failure Detector.

## TYPICAL APPLICATION CIRCUIT

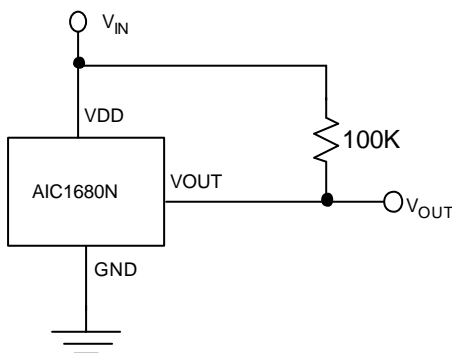

Voltage Level Indicator (N-ch Open-Drain Output)

## DESCRIPTION

The AIC1680 is an accurate, ultra-low power consumption voltage detector IC, fabricated with advanced CMOS process. The AIC1680 consists of a comparator, a voltage reference unit, a resistor divider, two output drivers, and a hysteresis circuit.

The consumption current is so low that it can often be ignored when compared to the battery self-discharge current. The values of detection and hysteresis voltage are set internally and are accurately controlled by trimming techniques. There are three types of output: N-ch open-drain, P-ch open-drain, and CMOS. Four types of package, TO-92, SOT-89, SOT-23 and SOT-23-5, are available to save board space.



**ORDERING INFORMATION**

AIC1680XXXCX

PACKAGING TYPE

- U: SOT-23
- X: SOT-89
- Z: TO-92
- V: SOT23-5

DETECTION VOLTAGE OPTIONAL

- 16: 1.6V
- 17: 1.7V
- ⋮
- 60: 6.0V

OUTPUT TYPE

- N: N-ch Open Drain
- P: P-ch Open Drain
- C: CMOS

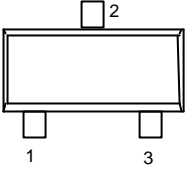
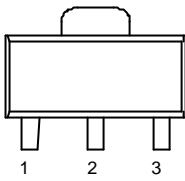
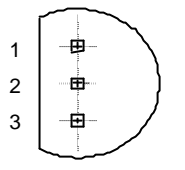
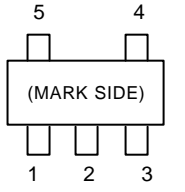
ORDER NUMBER	PIN CONFIGURATION
AIC1680CU (SOT-23)	FRONT VIEW 1: VOUT 2: VDD 3: GND 
AIC1680CX (SOT-89)	FRONT VIEW 1: VOUT 2: VDD 3: GND 
AIC1680CZ (TO-92)	FRONT VIEW 1: VOUT 2: VDD 3: GND 
AIC1680CV (SOT-23-5)	FRONT VIEW 1: VOUT 2: VDD 3: GND 4: NC 5: NC (MARK SIDE) 

**ABSOLUTE MAXIMUM RATINGS**

- Supply Voltage ..... 10V
- Output Voltage .....Vss-0.3 to 10V
- Operating Temperature Range ..... -30°C ~ 80°C
- Storage Temperature Range..... - 65°C ~ 150°C
- Lead Temperature (Soldering) 10 sec.....260°C
- Output Current .....20mA



**ELECTRICAL CHARACTERISTICS** (Test Conditions : Ta=25°C )

SYMBOL	PARAMETER	TEST CONDITIONS	MIN	TYP	MAX	UNIT
V <sub>DET</sub>	Detector Voltage		0.975	1.0	1.025	V <sub>DET</sub>
V <sub>HYS</sub>	Detector Threshold Hysteresis		0.03	0.05	0.07	V <sub>DET</sub>
I <sub>DD</sub>	Supply Current	V <sub>DD</sub> =2.0V V <sub>DD</sub> =3.0V V <sub>DD</sub> =4.5V V <sub>DD</sub> =6.0V V <sub>DD</sub> =10.0V		0.7 0.9 1.3 1.8 3.2	1.1 1.5 2.0 2.7 4.8	μA
V <sub>DD</sub>	Operation Voltage		1.5		10	V
I <sub>OUT</sub> (Nch)	Output Current	V <sub>DS</sub> =0.5V V <sub>DD</sub> =2.4V V <sub>DS</sub> =0.5V V <sub>DD</sub> =3.6V V <sub>DS</sub> =0.5V V <sub>DD</sub> =4.6V V <sub>DS</sub> =0.5V V <sub>DD</sub> =6.0V		3.24 5.85 7.74 10.44		mA
I <sub>OUT</sub> (Pch)	Output Current	V <sub>DS</sub> =-2.1V V <sub>DD</sub> =4.5V		3.5		mA
	Temperature Coefiencence			±150		ppm/°C
T <sub>DELAY</sub>	Output Delay Time				200	μS

**BLOCK DIAGRAM**

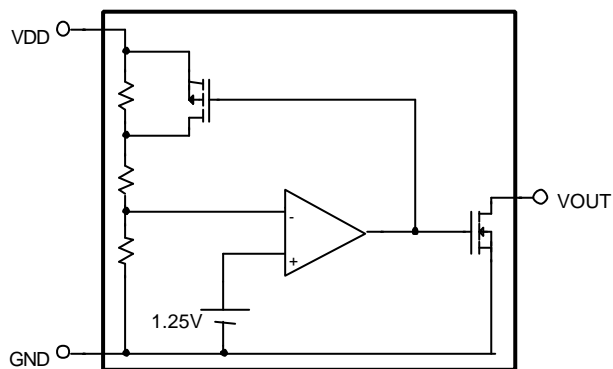

N-ch open drain output

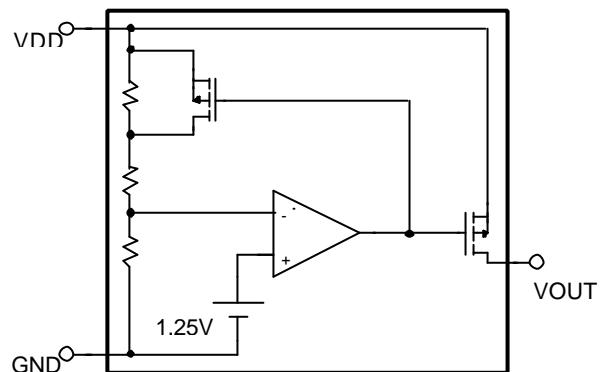

P-ch open drain output

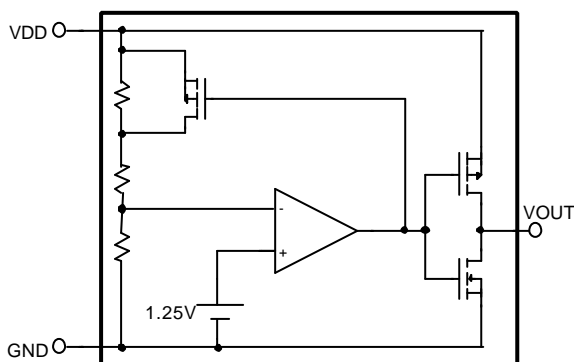

CMOS output



### PIN DESCRIPTIONS

V<sub>DD</sub>: Power Supply and Detected Voltage Input.

GND: Ground.

V<sub>out</sub>: Detector Output

### TYPICAL PERFORMANCE CHARACTERISTICS

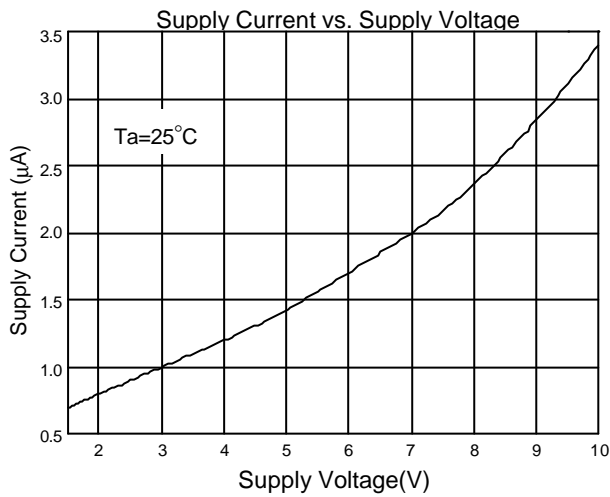

### N-ch Driver Sinking Current vs. V<sub>DS</sub>

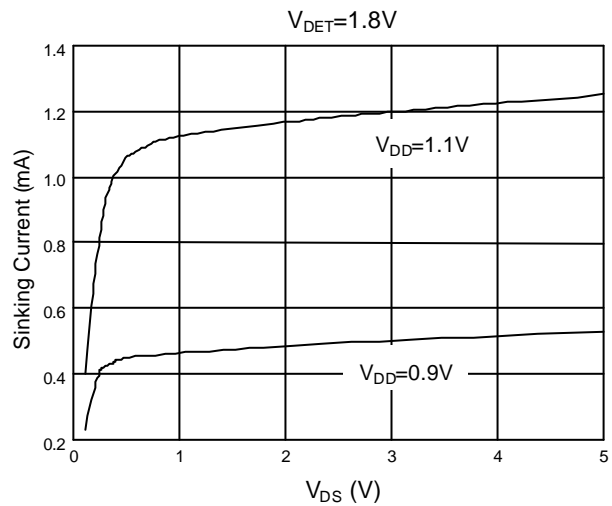
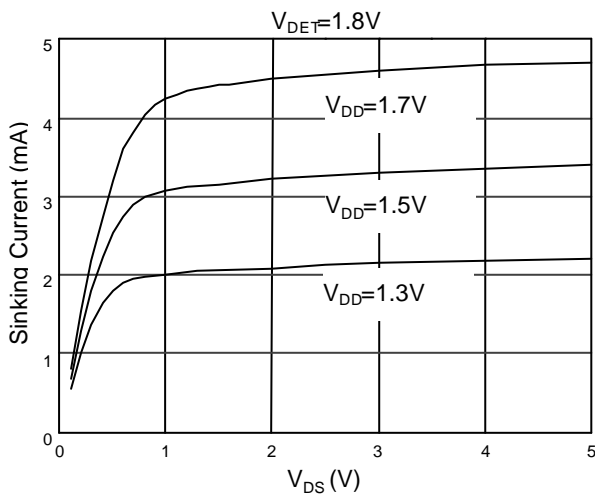



**TYPICAL PERFORMANCE CHARACTERISTICS (Continued)**

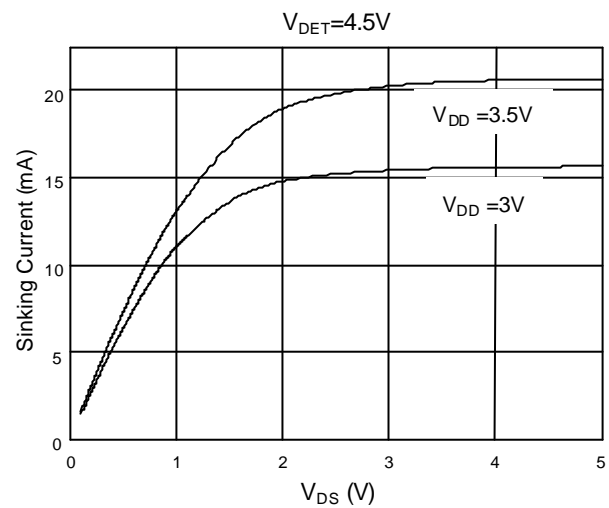
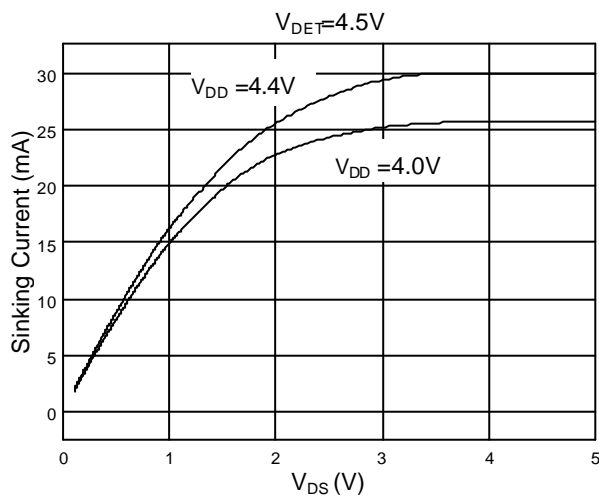
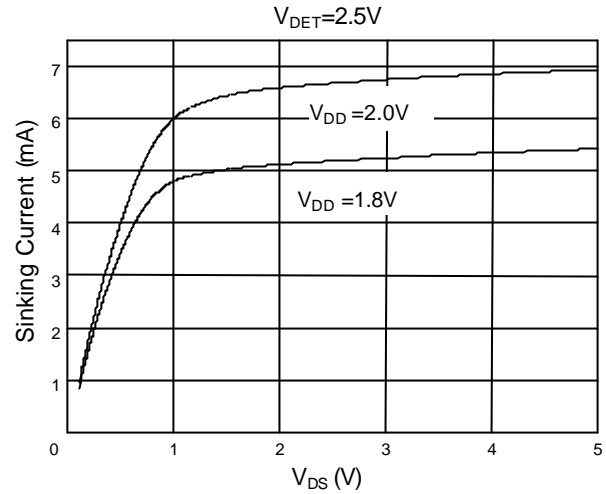
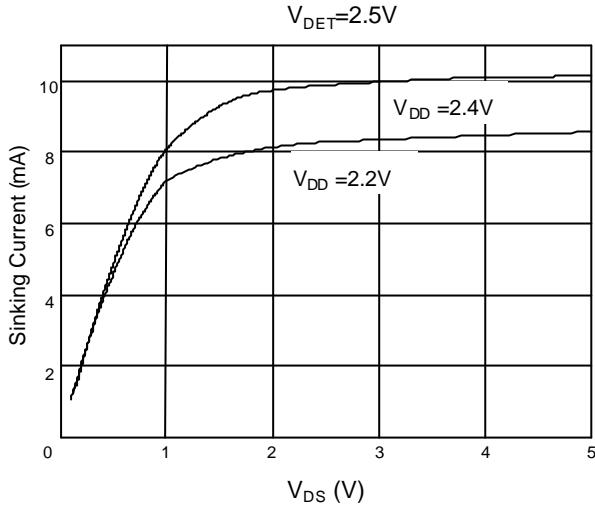

**P-ch Driver Output Current vs.  $V_{DS}$**

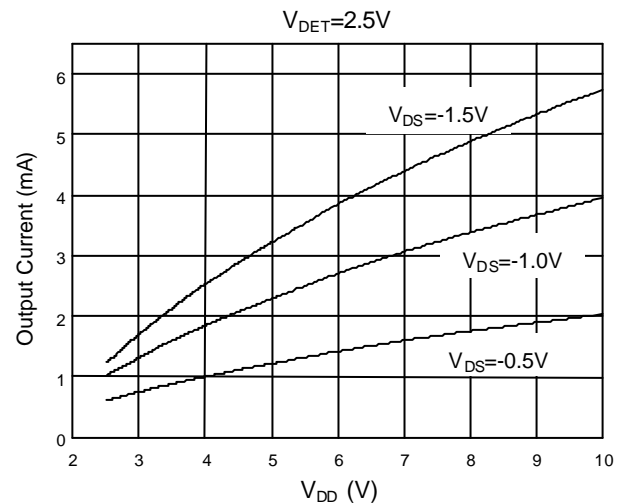
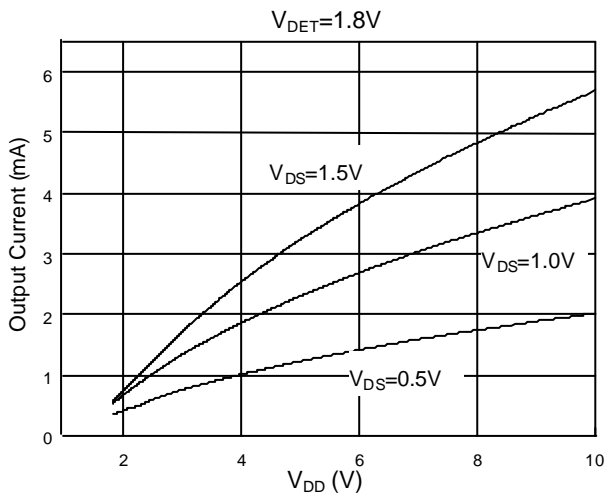



### TYPICAL PERFORMANCE CHARACTERISTICS (Continued)

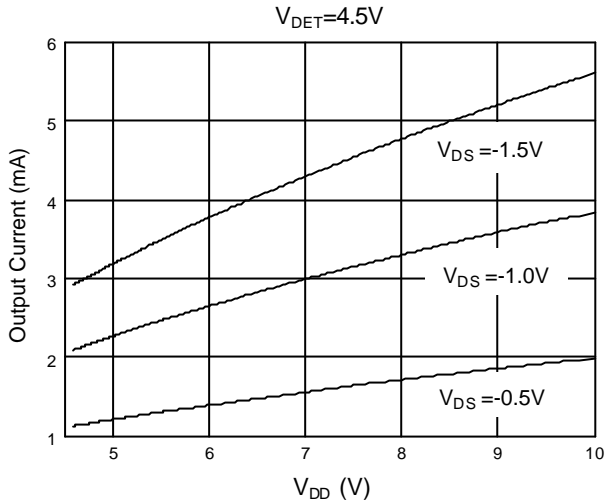

### APPLICATION INFORMATIONS

The timing diagram of V<sub>DD</sub> and V<sub>OUT</sub> is shown in below:

#### CMOS Type

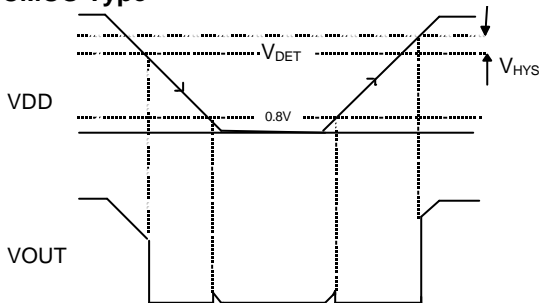

The guaranteed minimum operation voltage is 1.5V. As the supply voltage(V<sub>DD</sub>) is reduced below 1.5V, the performance degrades, N-ch or P-ch driving capacity degrades, and the supply current decreases. AIC1680 isn't functioning when V<sub>DD</sub> down to 0.8V.

#### NMOS Type

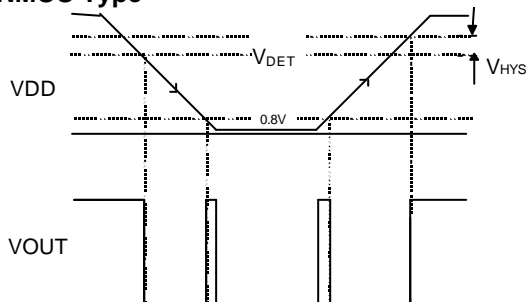



**PHYSICAL DIMENSIONS**

● SOT-23 (unit: mm)

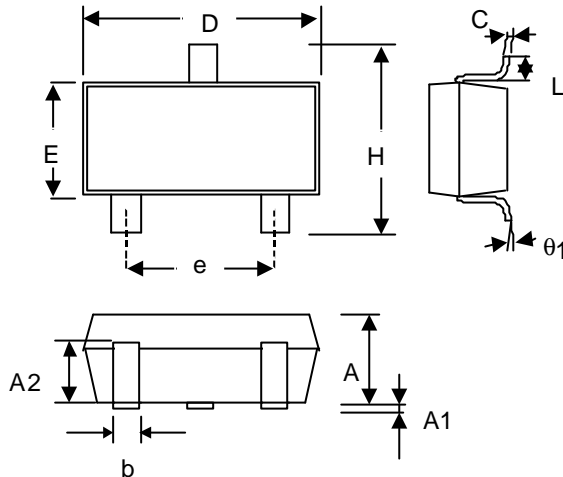

SYMBOL	MIN	MAX
A	1.00	1.30
A1	—	0.10
A2	0.70	0.90
b	0.35	0.50
C	0.10	0.25
D	2.70	3.10
E	1.40	1.80
e	1.90 (TYP)	
H	2.60	3.00
L	0.37	—
1	1°	9°

● SOT-23 Marking

Part No.	Marking
AIC1680-N16CU	U16N
AIC1680-P16CU	U16P
AIC1680-C16CU	U16C
AIC1680-N17CU	U17N
AIC1680-P17CU	U17P
AIC1680-C17CU	U17C
..... (0.1V INCREMENT)	

Part No.	Marking
AIC1680-N59CU	U59N
AIC1680-P59CU	U59P
AIC1680-C59CU	U59C
AIC1680-N60CU	U60N
AIC1680-P60CU	U60P
AIC1680-C60CU	U60C



● SOT-89 (unit: mm)

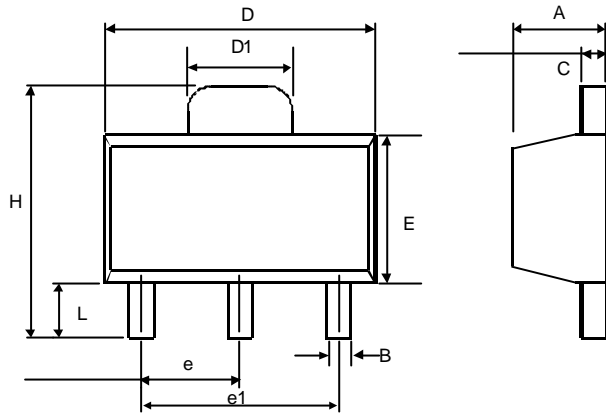

SYMBOL	MIN	MAX
A	1.40	1.60
B	0.36	0.48
C	0.35	0.44
D	4.40	4.60
D1	1.62	1.83
E	2.29	2.60
e	1.50 (TYP.)	
e1	3.00 (TYP.)	
H	3.94	4.25
L	0.89	1.20

● SOT-89 Marking

Part No.	Marking
AIC1680-N16CX	X16N
AIC1680-P16CX	X16P
AIC1680-C16CX	X16C
AIC1680-N17CX	X17N
AIC1680-P17CX	X17P
AIC1680-C17CX	X17C
..... (0.1V INCREMENT)	

Part No.	Marking
AIC1680-N59CX	X59N
AIC1680-P59CX	X59P
AIC1680-C59CX	X59C
AIC1680-N60CX	X60N
AIC1680-P60CX	X60P
AIC1680-C60CX	X60C

● TO-92 (unit: mm)

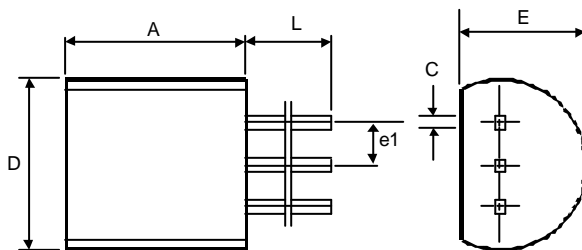

SYMBOL	MIN	MAX
A	4.32	5.33
C	0.38 (TYP.)	
D	4.40	5.20
E	3.17	4.20
e1	1.27 (TYP.)	
L	12.7	-



● SOT-23-5 (unit: mm)

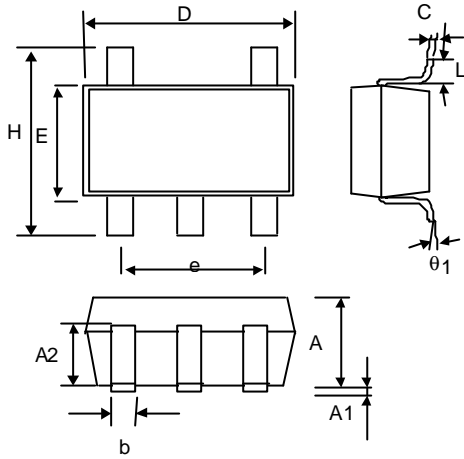

SYMBOL	MIN	MAX
A	1.00	1.30
A1	—	0.10
A2	0.70	0.90
b	0.35	0.50
C	0.10	0.25
D	2.70	3.10
E	1.40	1.80
e	1.90 (TYP)	
H	2.60	3.00
L	0.37	—
$\theta 1$	1°	9°

● SOT-23-5 Marking

Part No.	Marking
AIC1680-N16CV	V16N
AIC1680-P16CV	V16P
AIC1680-C16CV	V16C
AIC1680-N17CV	V17N
AIC1680-P17CV	V17P
AIC1680-C17CV	V17C
..... (0.1V INCREMENT)	

Part No.	Marking
AIC1680-N59CV	V59N
AIC1680-P59CV	V59P
AIC1680-C59CV	V59C
AIC1680-N60CV	V60N
AIC1680-P60CV	V60P
AIC1680-C60CV	V60C