



FEATURES

- Lowest Output Impedance (Typical 35Ω at $V_{IN}=5V$).
- Improved Direct Replacement for 7660.
- 1.5V to 6V Operation.
- No External Diode Required.
- Simple Conversion of +5V to ±5V.
- Low Quiescent Current (Typical 36μA at $V_{IN}=5V$).
- High Power Efficiency (Typical 98%)
- Boost Pin for Higher Switching Frequency.
- Improved SCR Latchup Protection.

APPLICATIONS

- RS-232 Power Supplies.
- Handheld Instruments.
- Data Acquisition Systems.
- Supply Splitter, $V_{OUT} = \pm V_{IN}/2$.
- Operational Amplifier Supplies.
- Panel Meter.

TYPICAL APPLICATION CIRCUIT

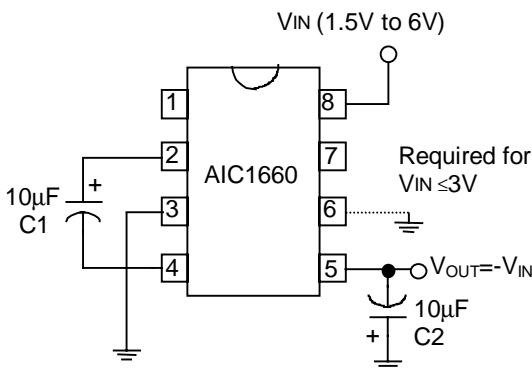

Negative Voltage Converter

DESCRIPTION

The AIC1660 is a monolithic CMOS switched capacitor voltage converter. Designed to be an improved direct replacement for the popular 7660 and LTC1044, the main function of the AIC1660 is to convert a positive input voltage in the range of 1.5V to 6V to the corresponding negative output voltage in the range of -1.5V to -6V. The input voltage can also be doubled ($V_{OUT} = 2V_{IN}$), divided ($V_{OUT} = (V_{IN} / 2)$), or multiplied ($V_{OUT} = \pm nV_{IN}$), as shown in application examples.

The chip contains a series DC power supply regulator, oscillator, control circuitry and four output power MOS switches. The frequency of oscillator can be lowered by the addition of an external capacitance to the OSC pin, or the oscillator may be over-driven by an external clock.

The boost function is available to raise the oscillator frequency to optimize performance in specific applications. The "LV" terminal may be tied to GND to improve low input voltage ($V_{IN} \leq 3V$) operation, or be left floating for input voltage larger than 3V to improve power dissipation.

The AIC1660 provides performance superior to previous designs by combining low output impedance, low quiescent current with high efficiency, and by eliminating diode drop voltage losses. The only required external components are two low cost electrolytic capacitors.

ORDERING INFORMATION

AIC1660 XX

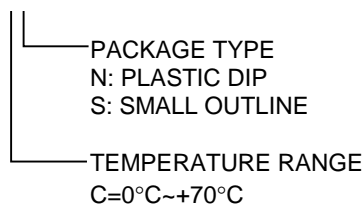

ORDER NUMBER	PIN CONFIGURATION
AIC1660CN (PLASTIC DIP)	TOP VIEW
AIC1660CS (PLASTIC SO)	



ABSOLUTE MAXIMUM RATINGS

Supply Voltage	6.0V
Input Voltage on Pin 1, 6 and 7	-0.3V ~V _{IN} + 0.3V
Operating Temperature Range	0°C~+70°C
Storage Temperature Range.....	-65°C~150°C

TEST CIRCUIT

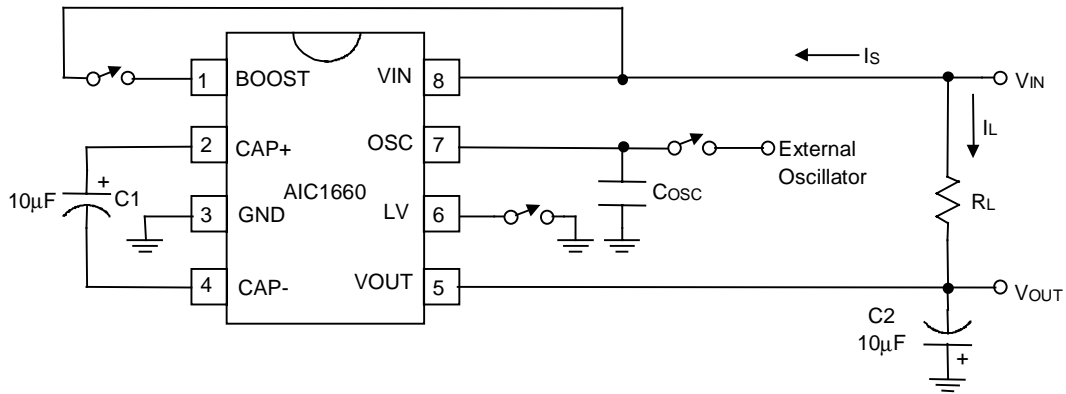

ELECTRICAL CHARACTERISTICS (V_{IN}=5.0V, Ta=25°C, OSC=free running, unless otherwise specified.)

PARAMETER	TEST CONDITIONS	SYMBOL	MIN.	TYP.	MAX.	UNIT
Supply Current	R _L = ∞	I _S		36	70	µA
Minimum Supply Voltage	R _L = ∞	V _{INL}	1.5			V
Maximum Supply Voltage	R _L = ∞	V _{INH}			9	V
Output Resistance	I _L =20mA, F _{OSC} =10KHZ	R _{OUT}		35	70	Ω
Oscillator Frequency	C _{OSC} =0 Pin 1 Floating or GND	F _{OSC}		10		KHz
	Pin 1=V _{IN}			50		
Power Efficiency	R _L = 5K, F _{OSC} =10KHZ	P _{EFF}	96	98		%
Voltage Conversion Efficiency	R _L = ∞	V _{OUTEFF}	98	99.9		%



TYPICAL PERFORMANCE CHARACTERISTICS (Ta=25°C)

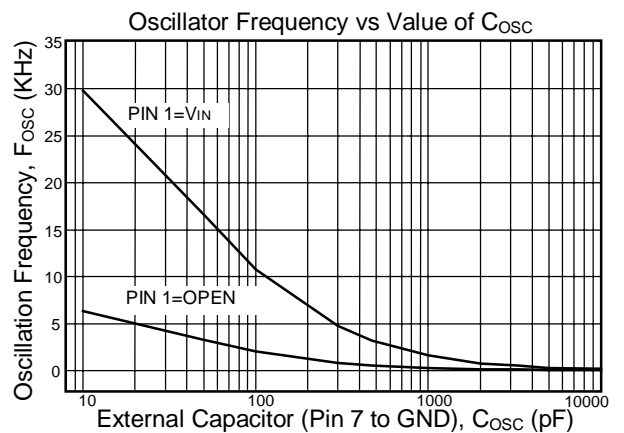
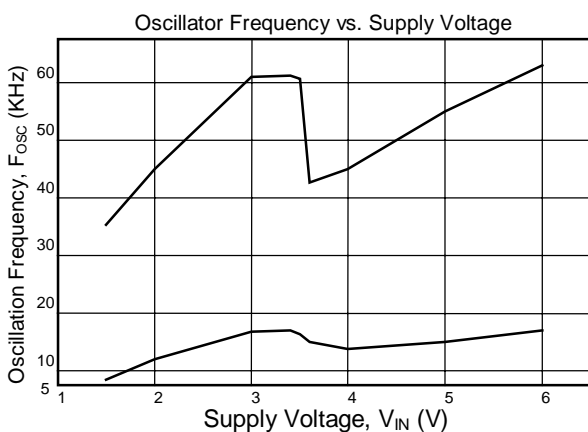
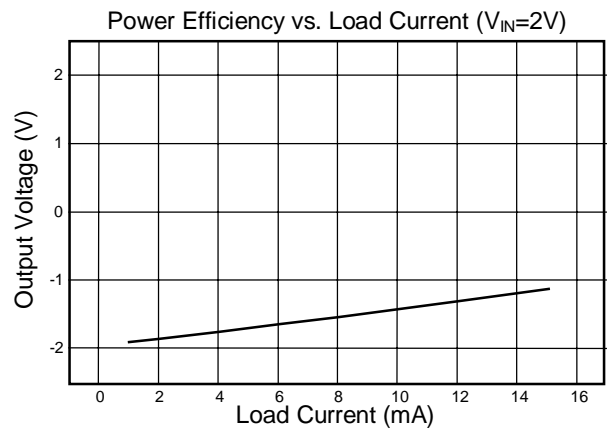
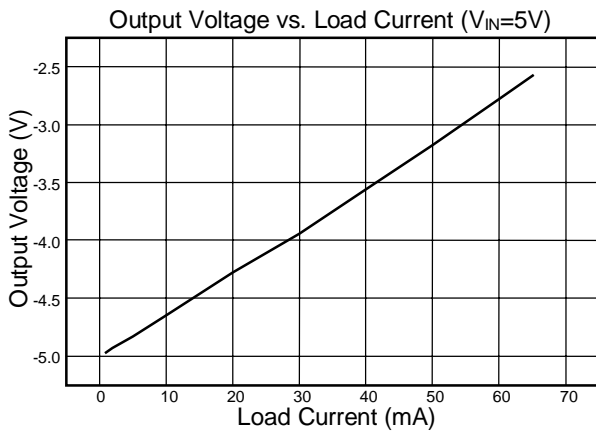
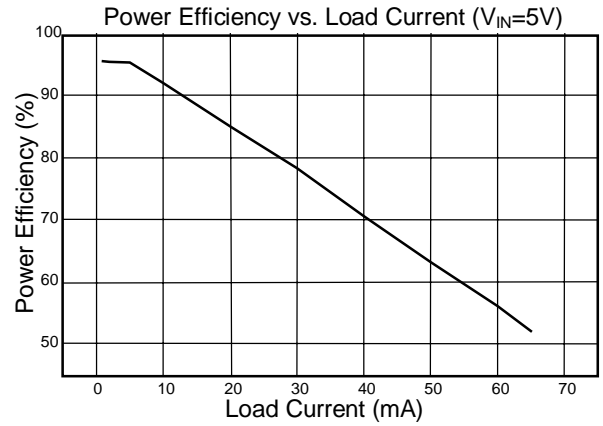
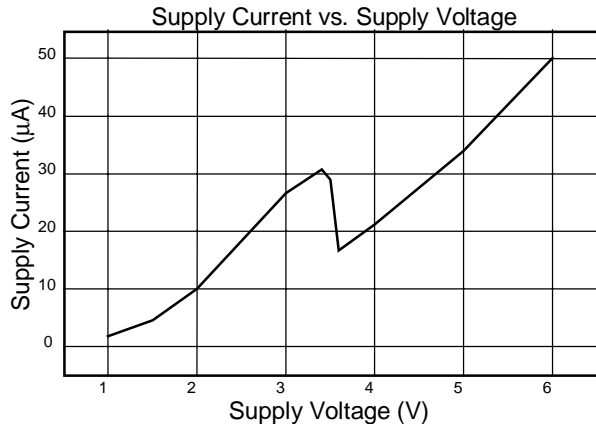



TYPICAL PERFORMANCE CHARACTERISTICS (CONTINUED)

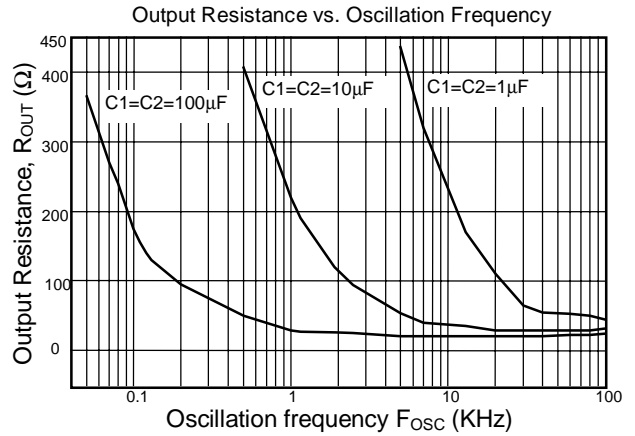
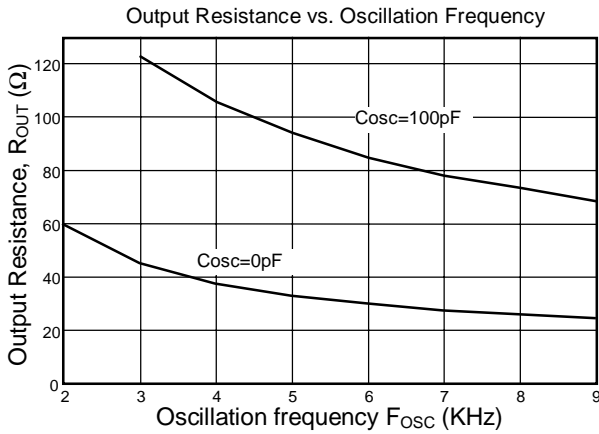

BLOCK DIAGRAM

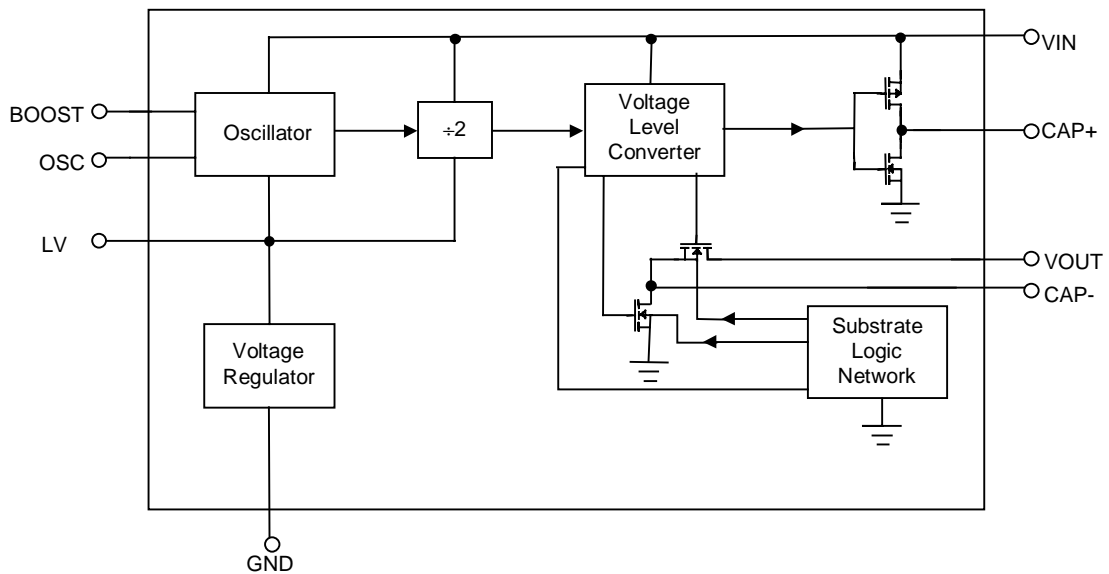

PIN DESCRIPTION

- PIN 1: BOOST- The frequency of oscillator will be 5 times if boost pin connect to V_{IN} .
- PIN 2: CAP+ - Connect to the positive side of flying capacitor.
- PIN 3: GND - Ground
- PIN 4: CAP- - To be connected to the negative side of flying capacitor.
- PIN 5: VOUT - Negative output voltage, typical connect a $10\mu F$ capacitor.

- PIN 6: LV - If V_{IN} blew 3V, LV should be tied to GND. For V_{IN} larger than 3V, LV can be floating.
- PIN 7: OSC - The frequency of oscillator can be lowered by the addition of an external capacitor to the OSC pin, or the oscillator may be over-driven by an external clock.
- PIN 8: VIN - Input supply.



APPLICATION EXAMPLES

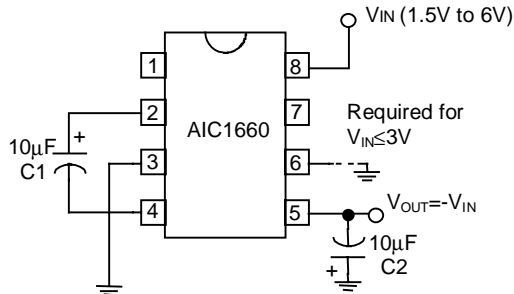

Fig. 1 Negative Voltage Converter

Fig. 1 shows a typical connection which will provide a negative supply from an available positive supply without the need of any external diodes. The LV pin should connect to ground for $V_{IN} \leq 3V$, or may be "floated" for $V_{IN} > 3V$

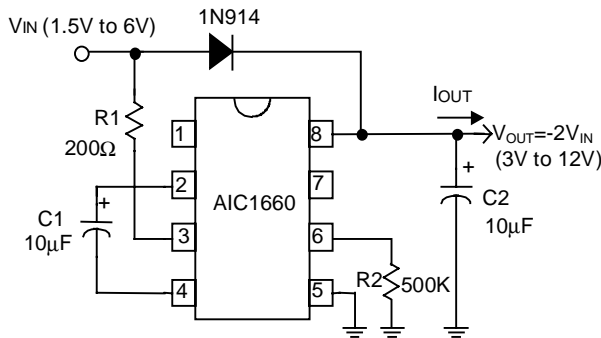

Fig. 2 Voltage Doubling

Fig. 2 shows a method of voltage doubling. Voltage doubling is achieved by simply rearranging the connection of the two external capacitors. An external 500KΩ resistor is required to ensure the oscillator will start.

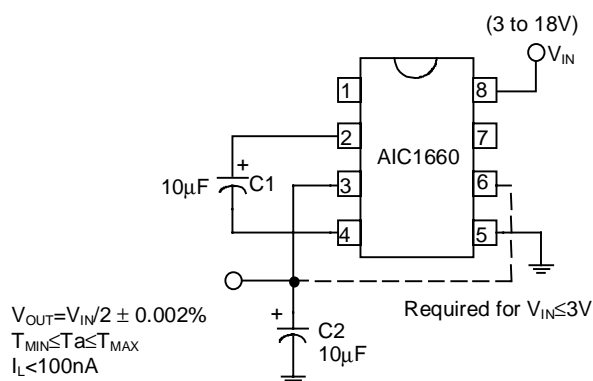
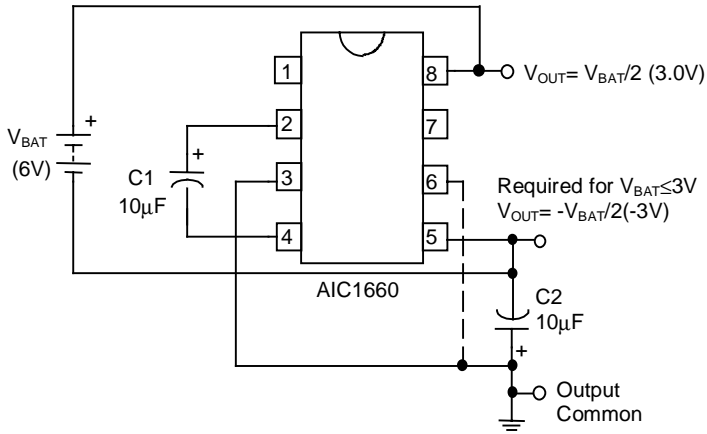

Fig. 3 Ultra Precision Voltage Divider

An ultra precision voltage divider is shown in Fig. 3. To achieve the 0.002% accuracy indicated, the load current should be kept below 100nA. However, with a slight loss in accuracy, the load current can be increased.



APPLICATION EXAMPLES (CONTINUED)



A common need in many system is to obtain (+) and (-) supplies from a single battery or power supply system. Where current requirement are low, the circuit shown in Fig. 4 is a simple solution.

Fig. 4 Battery Splitter

PHYSICAL DIMENSIONS

8 LEAD PLASTIC DIP

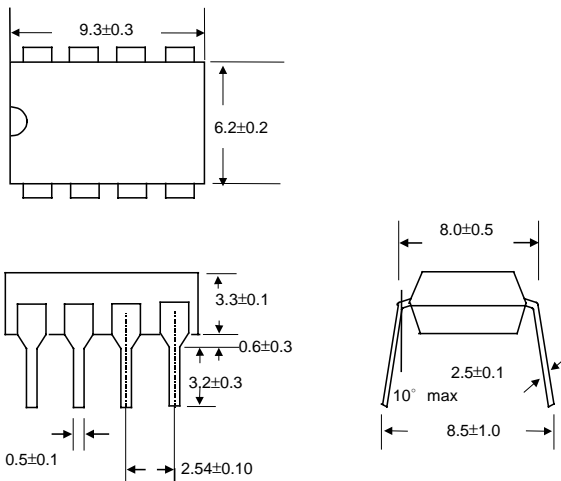

8 LEAD PLASTIC SO

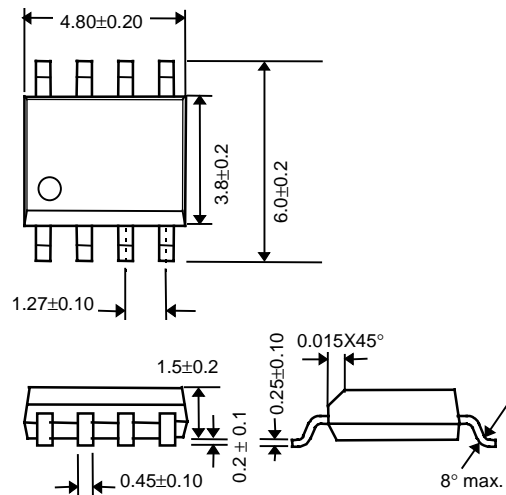

UNIT: mm