



FEATURES

- 4V to 20V Input Voltage Operation.
- Adjustable Output Voltage up to -40V.
- Low Quiescent Current at 100µA.
- Pulse Frequency Modulation Maintains High Efficiency (max. 90%).
- 100KHz to 320KHz Switching Frequency.
- Power-Saving Shutdown Mode (8µA Typical).
- High Efficiency with Low Cost External PNP Bipolar Transistor.

APPLICATIONS

- Negative LCD Contrast Bias for
 1. Notebook & Palmtop Computers.
 2. Pen-Based Data System.
 3. Portable Data Collection Terminals.
 4. Personal Digital Assistants.
- Negative Voltage Supply.

DESCRIPTION

The AIC1650 is a high performance inverting DC/DC converter, designed to drive an external power switch to generate programmable negative voltages. In the particularly suitable LCD bias contrast application, maximum efficiency of 90% can be achieved with low cost PNP bipolar transistor drivers. 4V to 20V input operation range allows the AIC1650 to be powered directly by the battery pack in most battery-operated applications for greater efficiency. Output voltage can be scaled to -40V or greater by two external resistors. A pulse frequency modulation scheme is employed to maintain high efficiency conversion under wide input voltage range. Quiescent current is about 100µA and can be reduced to 8µA in shutdown mode. Switching frequency being around 100KHz to 320KHz range, small size switching components are ideal for battery powered portable equipments, like notebook and palmtop computers.

TYPICAL APPLICATION CIRCUIT

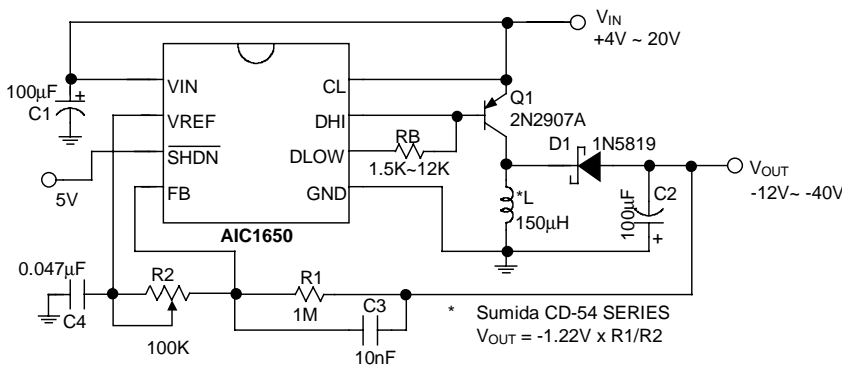

Negative LCD Contrast Bias Power Supply

ORDERING INFORMATION

AIC1650 XX

- PACKAGE TYPE
 - N: PLASTIC DIP
 - S: SMALL OUTLINE
- TEMPERATURE RANGE
 - C=0°C~+70°C

ORDER NUMBER	PIN CONFIGURATION
AIC1650CN (PLASTIC DIP)	TOP VIEW
AIC1650CS (PLASTIC SO)	



ABSOLUTE MAXIMUM RATINGS

- Supply Voltage 20V
SHDN Voltage 15V
Operating Temperature Range 0°C~ 70°C
Storage Temperature Range -65°C~ 150°C

TEST CIRCUIT

Refer to Typical Application Circuit.

ELECTRICAL CHARACTERISTICS (VIN=13V, Ta=25°C, unless otherwise specified.)

Table with 6 columns: PARAMETER, TEST CONDITIONS, MIN., TYP., MAX., UNIT. Rows include Input Voltage, Switch Off Current, VREF Voltage, VREF Source Current, DLOW 'ON Resistance', DHI 'ON Resistance', CL Threshold, Shutdown Threshold, and Shutdown Mode Current.

TYPICAL PERFORMANCE CHARACTERISTICS (Ta=25°C)

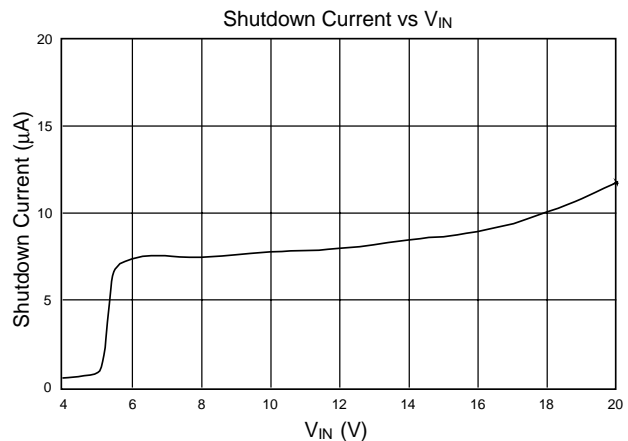
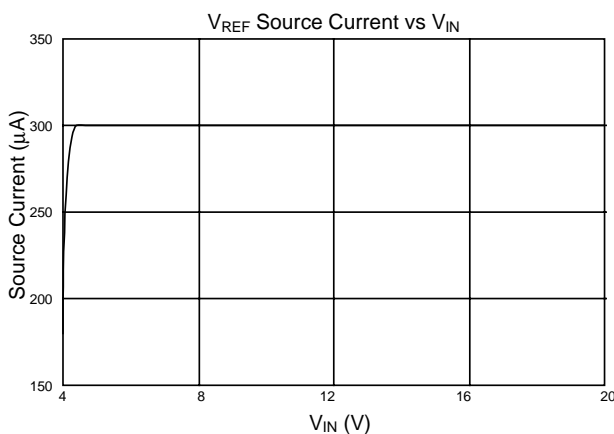



TYPICAL PERFORMANCE CHARACTERISTICS (CONTINUED)

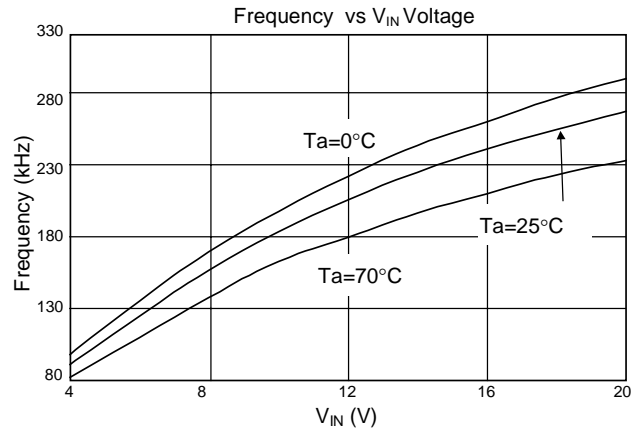
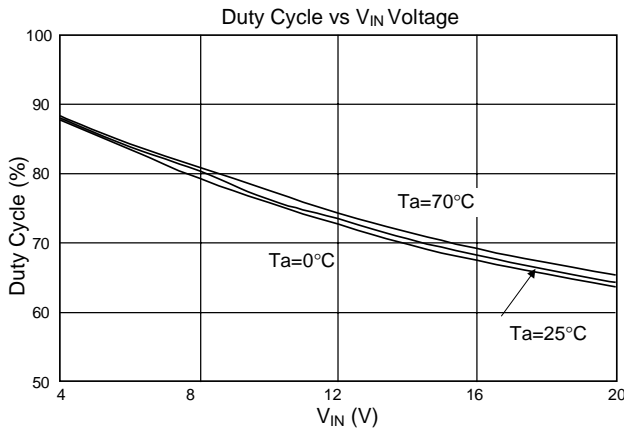

BLOCK DIAGRAM

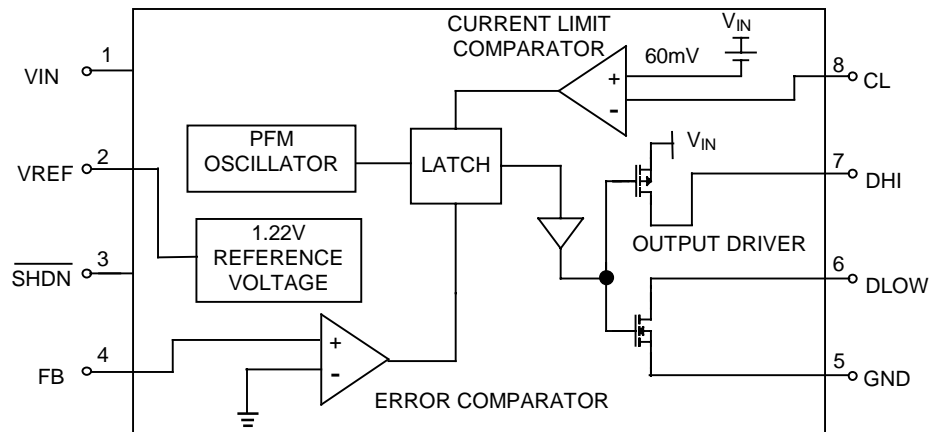

PIN DESCRIPTIONS

PIN 1: VIN - 4V to 20V input supply voltage.

PIN 2: VREF - 1.22V reference output. Bypass with a 0.047μF capacitor to GND. Sourcing capability is guaranteed to be greater than 250μA.

PIN 3: $\overline{\text{SHDN}}$ - Logic input to shutdown the chip.
 >1.5V = normal operation,
 GND = shutdown
 In shutdown mode DLOW and DHI pins are at high level.

PIN 4: FB - Feedback signal input to sense ground. Connecting a resistor R1 to VOUT and a resistor R2 to VREF pin yields the output voltage:

$$V_{\text{OUT}} = -(R1/R2) \times V_{\text{REF}}$$

PIN 5: GND - Power ground.

PIN 6: DLOW - Driver sinking output. Connected to DHI when using an external P-channel MOSFET. When using an external PNP bipolar transistor, connect a resistor RB from this pin to DHI. RB value depends on VIN, inductor and PNP bipolar transistor. By adjusting the RB value, efficiency can be optimized.

PIN 7: DHI - Driver sourcing output. Connect to gate of the external P-channel MOSFET or base of the PNP bipolar transistor.

PIN 8: CL - Current-limit input. This pin clamps the switch peak current to prevent over-current damage to the external switch.



APPLICATION INFORMATIONS

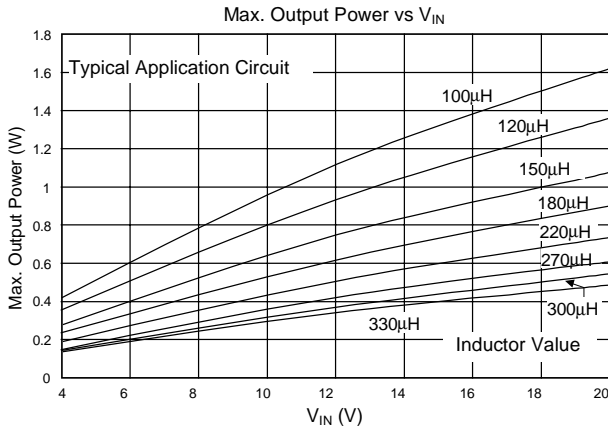

The typical application circuit generates an adjustable negative voltage for contrast bias of LCD displays. Efficiency and output power can be optimized by using appropriate inductor and switch. The following formulas provide a guideline for determining the optimal component values:

$$L = (11.1 - 0.15 \times V_{IN}) \times \frac{V_{IN}}{|I_{OUT}| \times |V_{OUT}|}$$

$$PNP : |V_{CEO}| > V_{IN} + |V_{OUT}|$$

$$|I_{C,MAX}| \geq 200 \times \frac{|I_{OUT}|}{V_{IN}}$$

$$|V_{CE}| < 0.4V \text{ at } I_C = 200 \times \frac{I_{OUT}}{V_{IN}}$$

$$\text{and } \beta = 10$$

$$R_B \cong 3 \times L \times (V_{IN} - 0.8)$$

where, units: V_{IN} & V_{OUT} in V, I_{OUT} in A, L in µH, R_B in Ω

APPLICATION EXAMPLES

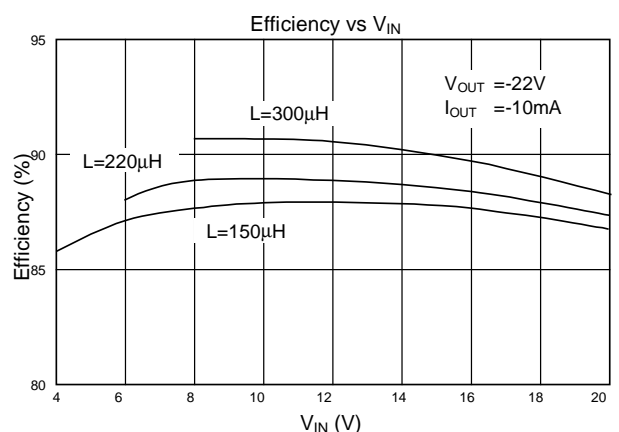
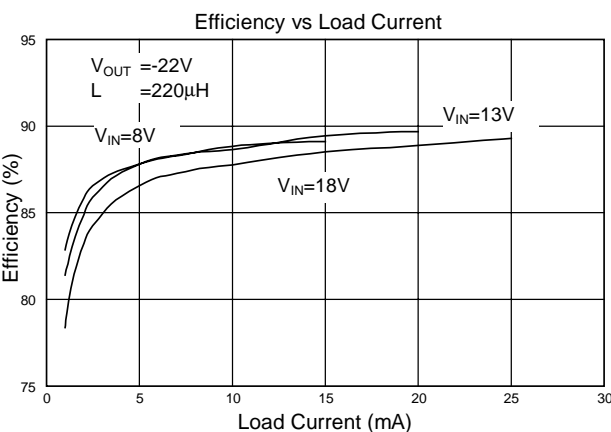
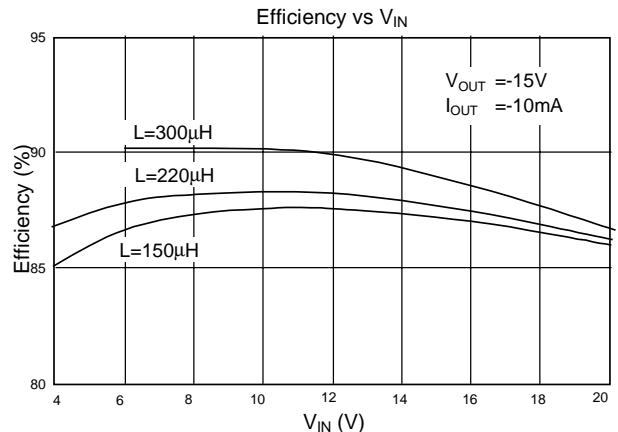
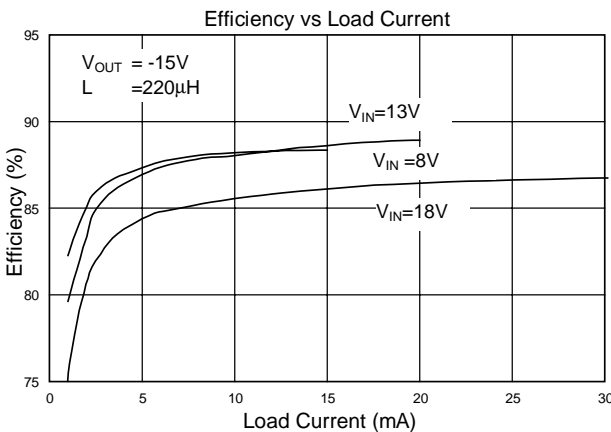



APPLICATION EXAMPLES (CONTINUED)

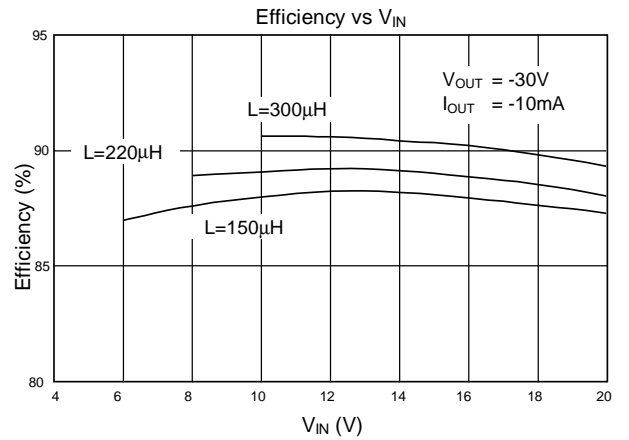
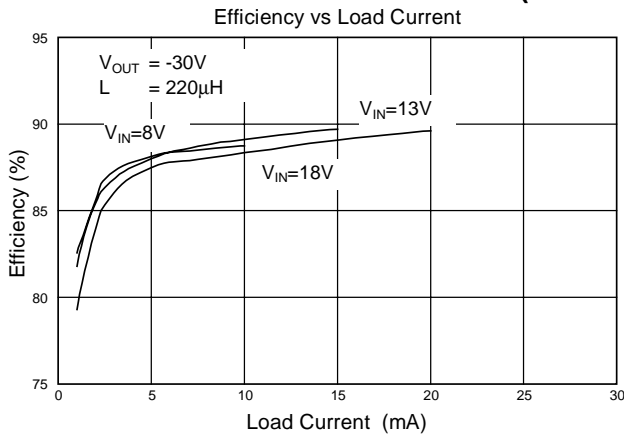

PHYSICAL DIMENSIONS

● 8 LEAD PLASTIC DIP

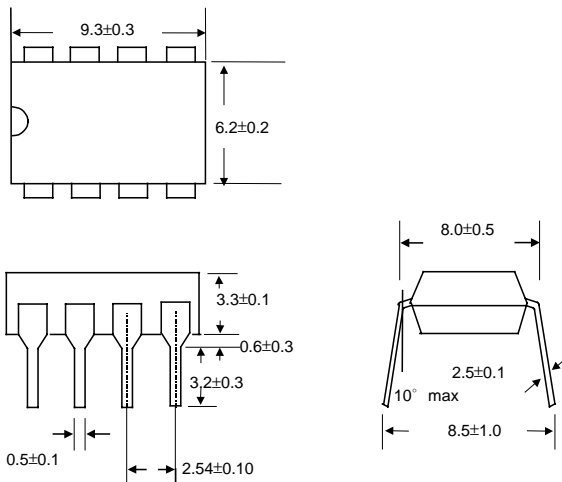

● 8 LEAD PLASTIC SO

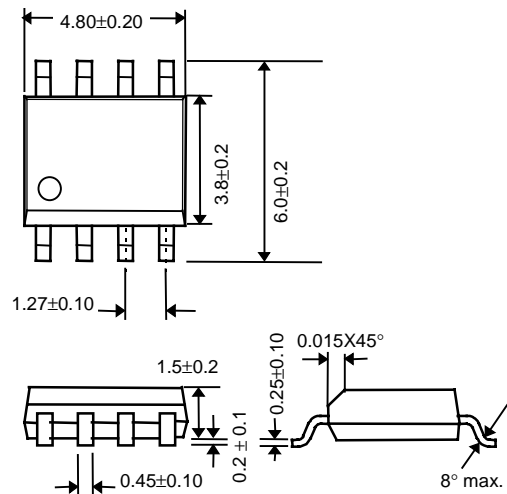

UNIT: mm