



FEATURES

- 4V to 20V Input Voltage Operation.
- High Efficiency (up to 95%).
- Low Quiescent Current at 90µA.
- Pulse-Skipping and Pulse-Frequency Modulation.
- Inputs-Uncommitted Current Sense Comparator.
- Duty Cycle Adjustable.
- 90KHz to 280KHz Oscillator Frequency.
- Power-Saving Shutdown Mode (8µA Typical).
- Push-Pull Driver Output.

APPLICATIONS

- Notebook 5V/3.3V Main Power
- Step-Down DC/DC Converter Module.
- Constant Current Source for Battery Chargers.

TYPICAL APPLICATION CIRCUIT

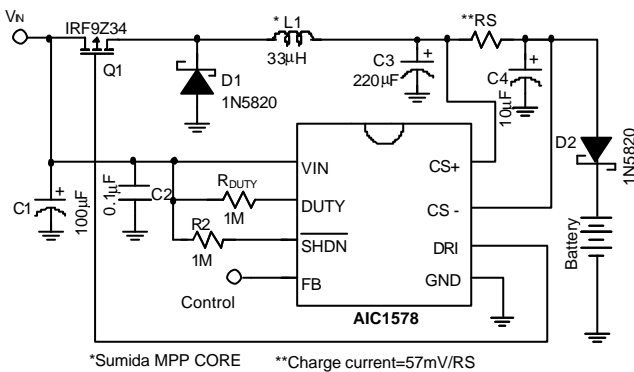

Constant Current Source for Battery Charger

DESCRIPTION

The AIC1578 is a high performance step-down DC/DC converter, designed to drive an external P-channel MOSFET to generate programmable output voltages. Two main schemes of Pulse-Skipping and Pulse-Frequency Modulation are employed to maintain low quiescent current and high conversion efficiency under wide ranges of input voltage and loading condition. The AIC1578 delivers 10mA to 2A of output current with 87%~93% efficiency at $V_{IN}=9V$, $V_{OUT}=5V$ condition. A current sense comparator with both inverting and non-inverting input uncommitted is included to provide the crucial function of either current limit protection or constant output current control. When the AIC1578 is used in a high-side current sensing step-down constant current source, the efficiency is typically greater than 90%. Duty cycle can be adjusted to greater than 90% by connecting a resistor from DUTY pin to V_{IN} . Quiescent current is about 90µA and can be reduced to 8µA in shutdown mode. Switching frequency being in around 90KHz to 280KHz range, small size switching components are ideal for battery powered portable equipment.

ORDERING INFORMATION

AIC1578 XX

PACKAGE TYPE
N: PLASTIC DIP
S: SMALL OUTLINE

TEMPERATURE RANGE
C: 0°C~+70°C

ORDER NUMBER	PIN CONFIGURATION
AIC1578CN (PLASTIC DIP)	TOP VIEW
AIC1578CS (PLASTIC SO)	

**ABSOLUTE MAXIMUM RATINGS**

V _{IN} Supply Voltage	20V
DUTY Voltage.....	20V
$\overline{\text{SHDN}}$ Voltage	15V
Operating Temperature Range	0°C~70°C
Storage Temperature Range	-65°C~ 150°C

TEST CIRCUIT

Refer to Fig. 1 circuit of Application Examples.

ELECTRICAL CHARACTERISTICS (V_{IN}= 13V, Ta=25°C, unless otherwise specified.)

PARAMETERS	CONDITIONS	MIN.	TYP.	MAX.	UNIT
Operation Voltage		4		20	V
Quiescent Current	V _{FB} = 1.5V		90	160	μA
Shutdown Mode Current	V $\overline{\text{SHDN}}$ = 0V		8	20	μA
Internal Reference Voltage		1.16	1.22	1.28	V
Driver Sinking "ON Resistance"			16		Ω
Driver Sourcing "ON Resistance"			11		Ω
Current Limit Sense Threshold	V _{CS+} = 13V	50	70	90	mV
Shutdown Threshold		0.8	1.5	2.4	V
$\overline{\text{SHDN}}$ Pin Leakage Current	V $\overline{\text{SHDN}}$ < 15V			1	μA
Duty Cycle	V _{DUTY} = V _{IN}		71		%
Oscillator Frequency	V _{DUTY} = V _{IN}		225		KHz



TYPICAL PERFORMANCE CHARACTERISTICS

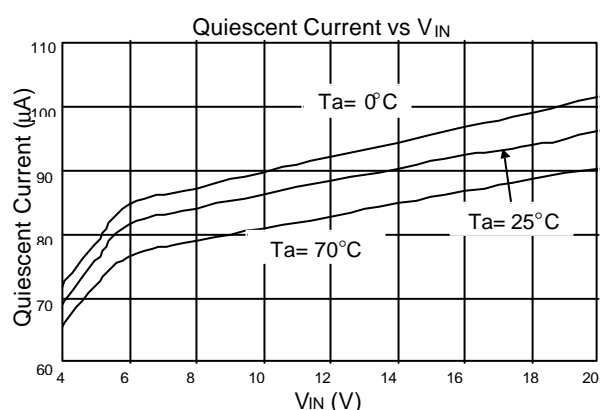
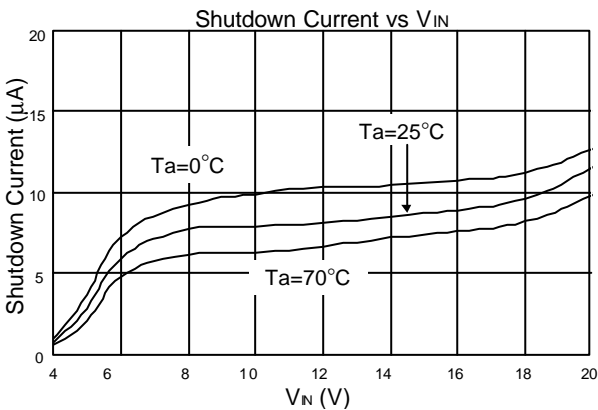
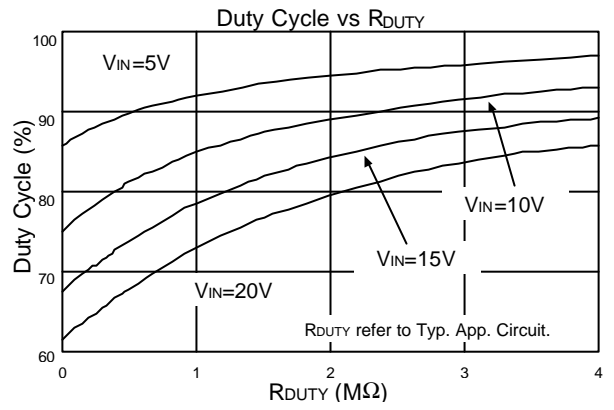
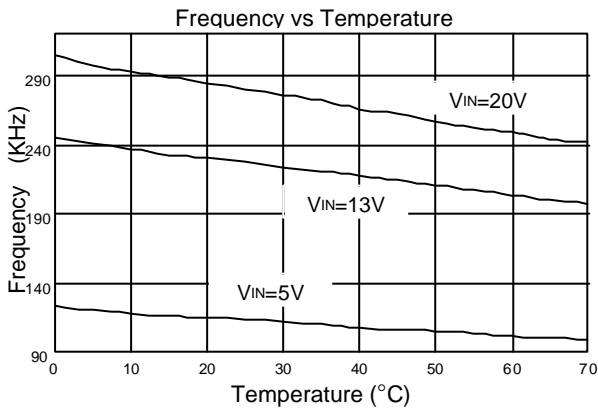
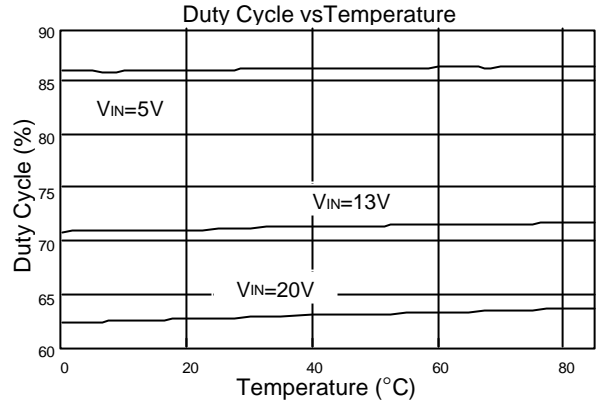
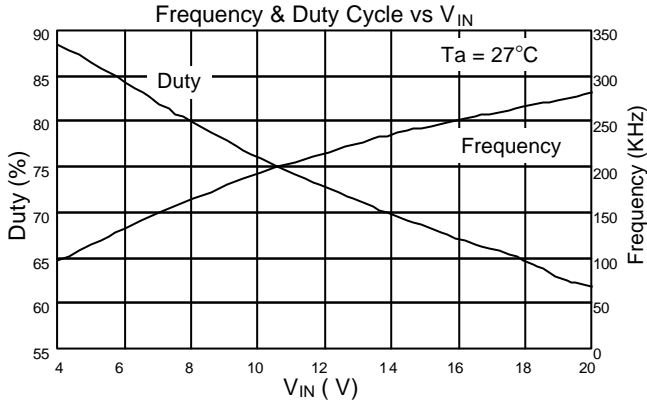



■ BLOCK DIAGRAM

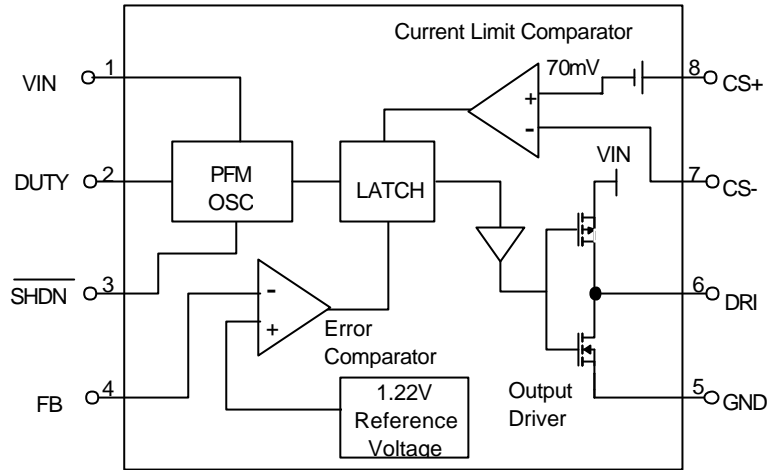

■ PIN DESCRIPTIONS

PIN 1: VIN - 4V to 20V input supply voltage.

PIN 2: DUTY - Duty cycle adjustment pin. To be tied to the VIN pin directly or through a resistor R_{DUTY} to adjust oscillator duty cycle. R_{DUTY} must be above $1M\Omega$ if $V_{IN}=20V$.
See TYPICAL PERFORMANCE CHARACTERISTICS.

PIN 3: \overline{SHDN} - Logical input to shutdown the chip:
 $V_{\overline{SHDN}} = \text{High}$ for normal operation.
 $V_{\overline{SHDN}} = \text{Low}$ for shutdown.
This pin should not be floating or forced to greater than 15V. In shutdown mode DRI pins is at high level.

PIN 4: FB - Feedback comparator input, to compare the feedback voltage with the internal reference voltage.

Connecting a resistor R1 to converter output node and a resistor R2 to ground yields the output voltage:

$$V_{OUT} = 1.22 \times (R1 + R2) / R2$$

PIN 5: GND - Power ground.

PIN 6: DRI - Push-pull driver output to drive an external P-channel MOSFET or PNP transistor. When driving a PNP bipolar transistor, a base resistor and a capacitor to the base of PNP are recommended.

PIN 7: CS- - Current sense comparator inverting input, not to exceed V_{IN} voltage.

PIN 8: CS+ - Current sense comparator non-inverting input, not to exceed V_{IN} voltage.



APPLICATION EXAMPLES

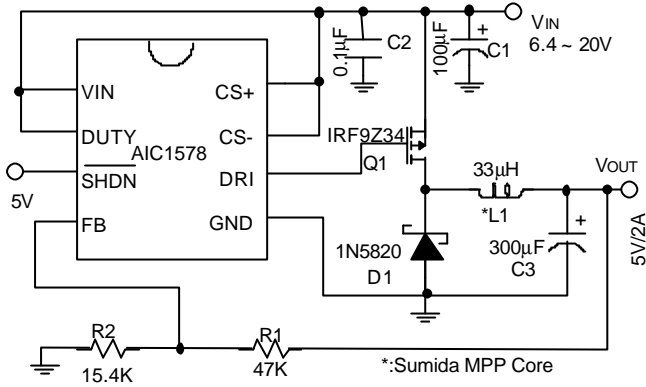

Fig. 1 5V Step-Down Converter

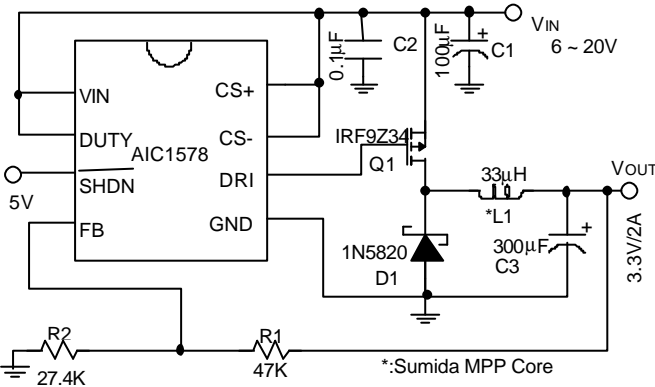
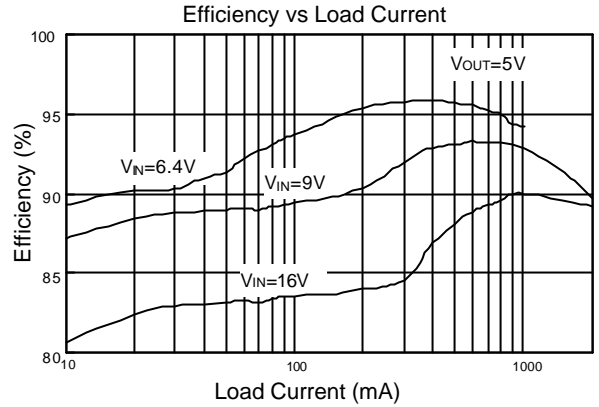
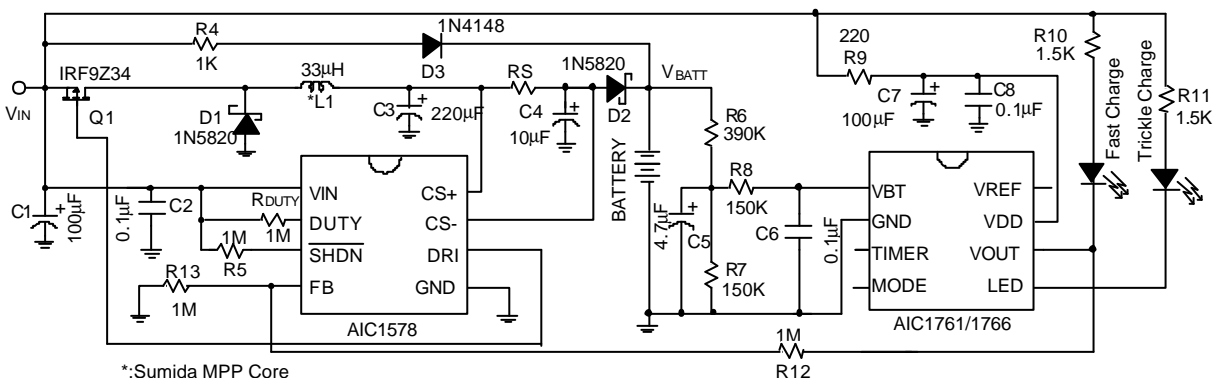
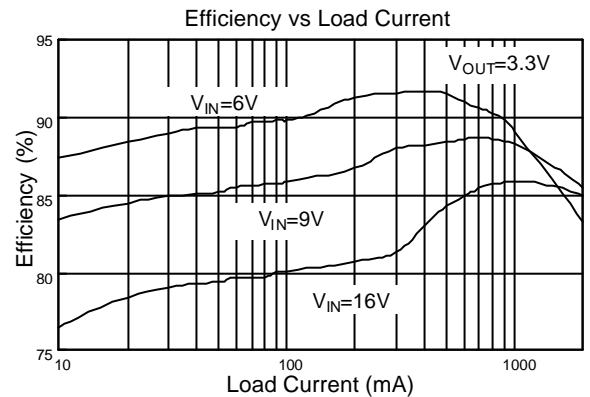

Fig. 2 3.3V Step-Down Converter



NOTE: $R_S = 0.1\Omega$, charge current = $0.5A \pm 10\%$, $V_{IN} > V_{BATT} + 3.5V$
 $R_S = 0.05\Omega$, charge current = $1A \pm 10\%$, $V_{IN} > V_{BATT} + 4V$
 $R_S = 0.033\Omega$, charge current = $1.5A \pm 10\%$, $V_{IN} > V_{BATT} + 4.5V$
 Efficiency > 90%, measured at CS- node

Fig. 3 Battery Charge Circuit with High-Side Current Sensing Constant Current Source



PHYSICAL DIMENSIONS

● **8 LEAD PLASTIC SO (unit: mm)**

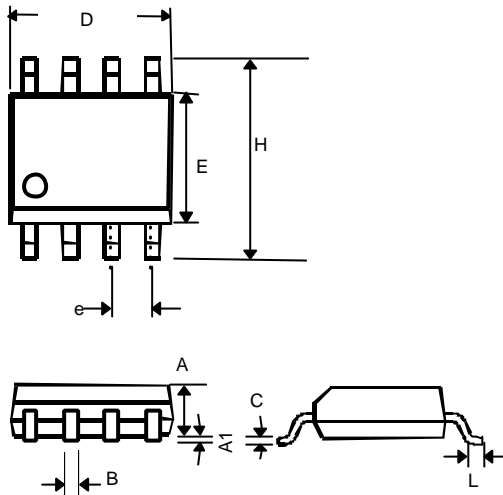

SYMBOL	MIN	MAX
A	1.35	1.75
A1	0.10	0.25
B	0.33	0.51
C	0.19	0.25
D	4.80	5.00
E	3.80	4.00
e	1.27(TYP)	
H	5.80	6.20
L	0.40	1.27

● **8 LEAD PLASTIC DIP (unit: mm)**

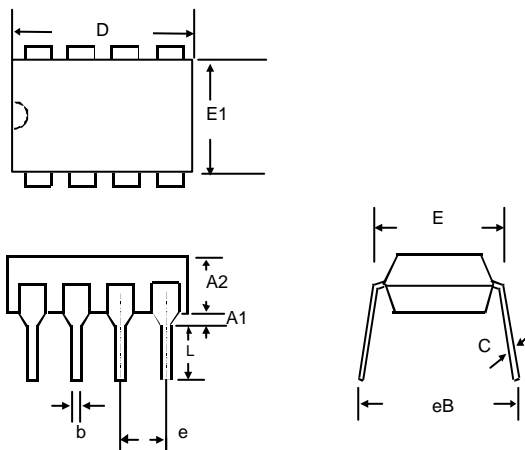

SYMBOL	MIN	MAX
A1	0.381	—
A2	2.92	4.96
b	0.35	0.56
C	0.20	0.36
D	9.01	10.16
E	7.62	8.26
E1	6.09	7.12
e	2.54 (TYP)	
eB	—	10.92
L	2.92	3.81