



FEATURES

- 200mΩ (5V Input) High-Side MOSFET Switch.
- 500mA Continuous Load Current per Channel.
- 110μA Typical On-State Supply Current.
- 1μA Typical Off-State Supply Current.
- Current-Limit / Short Circuit Protection.
- Thermal Shutdown Protection under Overcurrent Condition.
- Undervoltage Lockout Ensures that Switch is off at Start Up.
- Output can be Forced Higher than Input (Off-State).
- Slow Turn ON and Fast Turn OFF.

DESCRIPTION

The AIC1520 is an integrated high-side power switch for self-powered and bus-powered Universal Serial Bus (USB) applications. The high-side switch is a MOSFET with 200mΩ $R_{DS(ON)}$, which meets USB voltage drop requirements for maximum transmission wire length.

Output current is typically limited to 1A, well below the 5A safety requirement, and thermal shutdown function shuts the switch off to prevent damage under overcurrent conditions.

APPLICATIONS

- Motherboard USB Management.
- USB Power Management.
- Hot Plug-In Power Supplies.
- Battery-Charger Circuit.

Guaranteed minimum output rise time limits inrush current during hot plug-in, minimizing EMI and preventing the voltage at upstream port from dropping excessively.

TYPICAL APPLICATION CIRCUIT

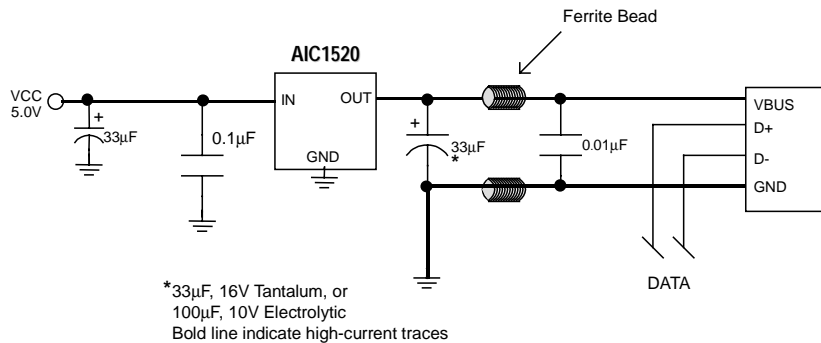

USB High-Side Power Switch

ORDERING INFORMATION

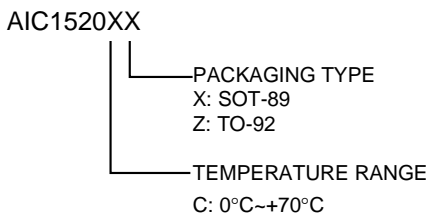

ORDER NUMBER	PIN CONFIGURATION
AIC1520CX (SOT-89)	FRONT VIEW 1: VIN 2: GND 3: VOUT
AIC1520CZ (TO-92)	TOP VIEW 1: VIN 2: GND 3: VOUT



■ ABSOLUTE MAXIMUM RATINGS

Supply Voltage (V_{IN}) 7.0V
 Operating Temperature Range -20°C ~ 80°C
 Storage Temperature Range -65°C ~ 150°C

■ ELECTRICAL CHARACTERISTICS ($V_{IN}= 5V$, $T_a=25^{\circ}C$, unless otherwise specified.)

PARAMETERS	CONDITIONS	MIN.	TYP.	MAX.	UNIT
Supply Current	Switch Off, OUT=Open		0.75		μA
	Switch On, OUT=Open		110		
Output MOSFET Resistance			200		$m\Omega$
Output Turn-On Rise Delay	$R_L = 10\Omega$ each Output		100		μS
Output Turn-On Rise Time	$R_L = 10\Omega$ each Output		1000	2500	μS
Output Leakage Current				10	μA
Current Limit Threshold		0.6	1.0	1.25	A
Thermal Limit			110		$^{\circ}C$
UVLO Threshold	V_{IN} Increasing		2.6		V
	V_{IN} Decreasing		2.4		



■ BLOCK DIAGRAM

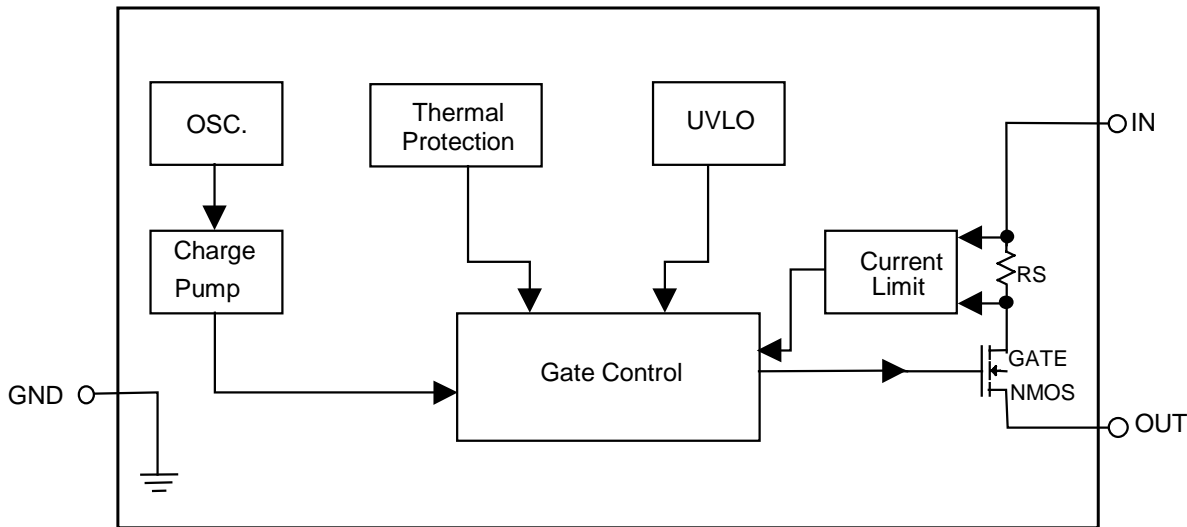

■ PIN DESCRIPTION

PIN 1: IN - Power supply input.
PIN 2: GND - Chip power ground.

PIN 3: OUT - MOSFET switch output.

■ APPLICATION INFORMATION

● Current Limit

The current limit threshold is preset internally. It protects the output MOSFET switches from damage due to undesirable short circuit conditions or excess inrush current often encountered during hot plug-in. The low limit of the current limit threshold of the AIC1520 allows a minimum current of 0.5A through the MOSFET switches.

● Thermal Protection

When the chip temperature exceeds 135°C, the thermal protection function works. A hysteresis of 45°C events the MOSFET from turning back on until the chip temperature drops to below 90°C.

● Supply Filtering

A 0.1µF to 1µF bypass capacitor from IN to GND, located near the device, is strongly recommended to control supply transients. Without a bypass capacitor, an output short may cause sufficient ringing on the input (from supply lead inductance) to damage internal control circuitry.

● Transient Droop Requirements

USB support dynamic attachment (hot plug-in) of peripherals. A current surge is caused by the input capacitance of downstream device. Ferrite beads are recommended in series with all power and ground connector pins. Ferrite beads reduce EMI and limit the inrush current during hot-attachment by filtering high-frequency signals.

● Short Circuit Transient

Bulk capacitance provides the short-term transient current needed during a hot-attachment event. With a 33µF, 16V tantalum or 100µF, 10V electrolytic capacitor mounted close to downstream connector should provide transient drop protection.

● Printed Circuit Layout

The power circuitry of USB printed circuit boards requires a customized layout to maximize thermal dissipation and to minimize voltage drop and EMI.



■ PHYSICAL DIMENSIONS

● SOT-89

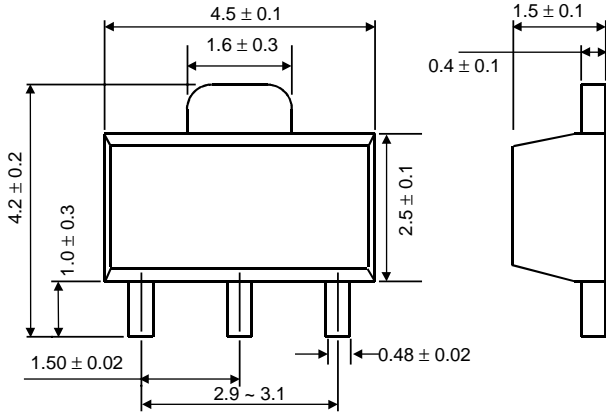

● TO-92

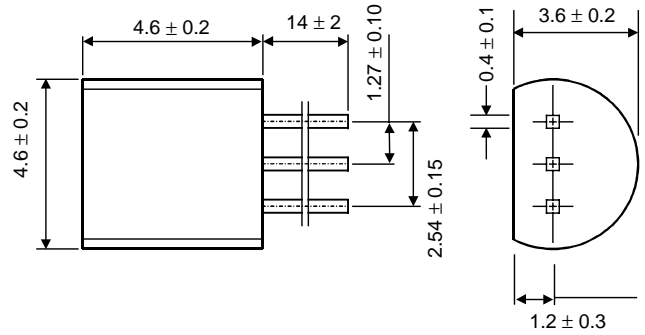

UNIT: mm