



### FEATURES

- Dropout Voltage 1.2V at 800mA Output Current.
- Fast Transient Response.
- Line Regulation typically at 0.015%.
- Load Regulation typically at 0.1%.
- Internal Thermal and Current Limiting.
- Adjustable Output Voltage or Fixed 2.85V, 3.3V, 5V.
- Standard 3-Pin Power Packages.

### APPLICATIONS

- SCSI-2 Active Terminator.
- Post Regulator for Switching Supply.
- Battery Chargers.
- Constant-Current Regulators.
- PC Add-On Card.

### DESCRIPTION

The AIC1117 is a low dropout three terminal regulator with 800mA output current capability. The output voltage is adjustable with the use of a resistor divider. For fixed output voltage versions, the output voltage is internally set at 2.85V, 3.3V or 5V. Dropout is guaranteed at a maximum of 1.3V at maximum output current. Its low dropout voltage and fast transient response make it ideal for low voltage microprocessor applications. Internal current and thermal limiting provides protection against any overload condition that would create excessive junction temperatures.

### TYPICAL APPLICATION CIRCUIT

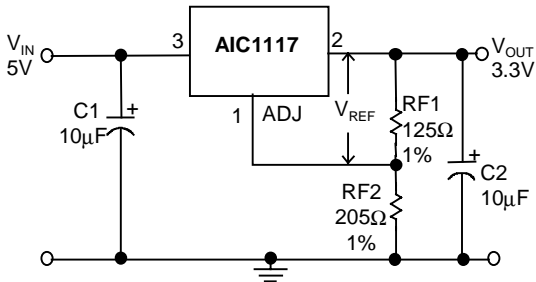

Adjustable Voltage Regulator

$$V_{REF} = V_{OUT} - V_{ADJ} = 1.25V \text{ (typ.)}$$

$$V_{OUT} = V_{REF} \times (1 + RF2/RF1) + I_{ADJ} \times RF2$$

$$I_{ADJ} = 55\mu A \text{ (typ.)}$$

- (1) C1 needed if device is far away from filter capacitors.
- (2) C2 required for stability.

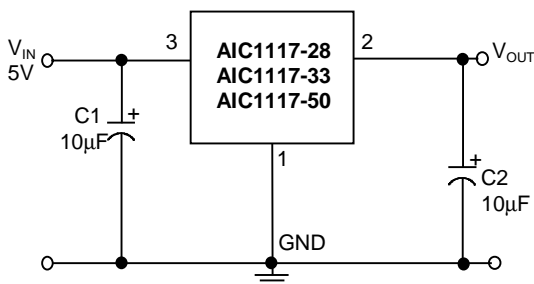

Fixed Voltage Regulator



### ORDERING INFORMATION

AIC1117-XXXX

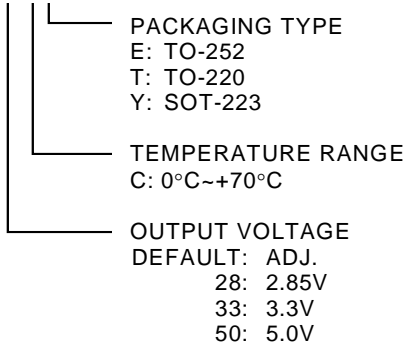

ORDER NUMBER	PIN CONFIGURATION	
AIC1117CE (TO-252)	FRONT VIEW 1: ADJ (GND) 2: VOUT (TAB) 3: VIN	
AIC1117CT (TO-220)	FRONT VIEW 1: ADJ (GND) 2: VOUT (TAB) 3: VIN	
AIC1117CY (SOT-223)	FRONT VIEW 1: ADJ (GND) 2: VOUT (TAB) 3: VIN	

### ABSOLUTE MAXIMUM RATINGS

VIN pin to ADJ/ GND pin	.....	7V
Operating Junction Temperature Range	.....	0°C ~ 125°C
Storage Temperature Range	.....	- 65°C ~ 150°C
Thermal Resistance (Junction to Case)	TO-220	..... 3°C /W
	TO-252	.....12.5°C /W
	SOT-223	.....15°C /W
Lead Temperature (Soldering) 10 sec.	.....	260°C

### TEST CIRCUIT

Refer to TYPICAL APPLICATION CIRCUIT.

**ELECTRICAL CHARACTERISTICS** ( $V_{IN}=5V$ ,  $T_J=25^{\circ}C$ ,  $I_O=10mA$ , Unless otherwise specified)

PARAMETER	TEST CONDITIONS	MIN.	TYP.	MAX.	UNIT
Reference Voltage	AIC1117 (Adj.) $T_J=25^{\circ}C$ $0^{\circ}C \leq T_J \leq 125^{\circ}C$	1.238 1.225	1.25 1.25	1.262 1.275	V
Output Voltage	AIC1117-28, $V_{IN}=5V$ AIC1117-33, $V_{IN}=5V$ AIC1117-50, $V_{IN}=7V$	2.82 3.26 4.95	2.85 3.30 5.00	2.88 3.33 5.05	V
Line Regulation	$2.65 \leq V_{IN} \leq 7V$ $T_J=25^{\circ}C$ $0^{\circ}C \leq T_J \leq 125^{\circ}C$		0.015 0.035	0.2 0.2	%
Load Regulation	$T_J=25^{\circ}C$ , $I_O=10\sim 800mA$ $0^{\circ}C \leq T_J \leq 125^{\circ}C$		0.1 0.2	0.3 0.4	%
Dropout Voltage	$\Delta V_{OUT}, \Delta V_{REF}=1\%$ $10mA \leq I_O \leq 800mA$ $0^{\circ}C \leq T_J \leq 125^{\circ}C$		1.2	1.3	V
Current Limit	$0^{\circ}C \leq T_J \leq 125^{\circ}C$	0.85		2.0	A
Adjusted Pin Current ( $I_{ADJ}$ )	$2.65 \leq V_{IN} \leq 7V$ $10mA \leq I_O \leq 800mA$ $0^{\circ}C \leq T_J \leq 125^{\circ}C$		55	120	$\mu A$
Adjusted Pin Current Change ( $\Delta I_{ADJ}$ )	$2.65 \leq V_{IN} \leq 7V$ $10mA \leq I_O \leq 800mA$ $0^{\circ}C \leq T_J \leq 125^{\circ}C$		0.2	5	$\mu A$
Temperature Stability	$I_O=0.5A$ $0^{\circ}C \leq T_J \leq 125^{\circ}C$		0.5		%
Minimum Load Current	$0^{\circ}C \leq T_J \leq 125^{\circ}C$		5	10	mA
RMS Output Noise (% of $V_{OUT}$ )	$10Hz \leq f \leq 10KHz$		0.003		%
Ripple Rejection Ratio	120Hz input ripple $C_{OUT}=25\mu F$	60	72		dB



### TYPICAL PERFORMANCE CHARACTERISTICS

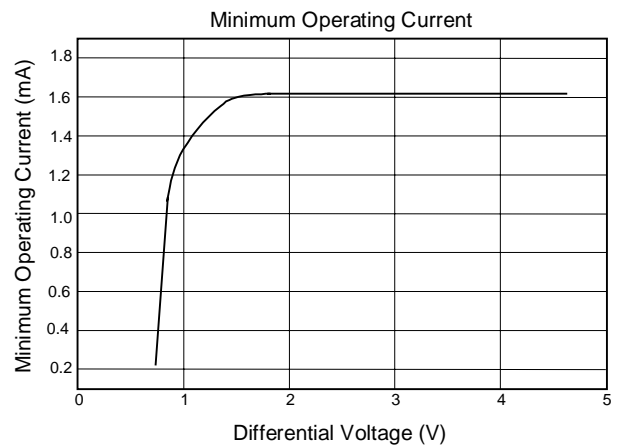
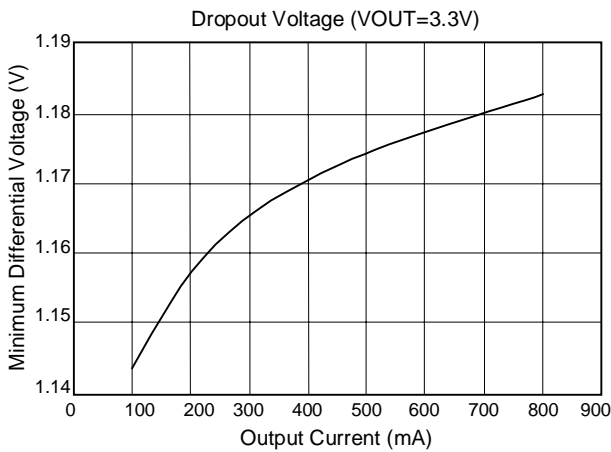
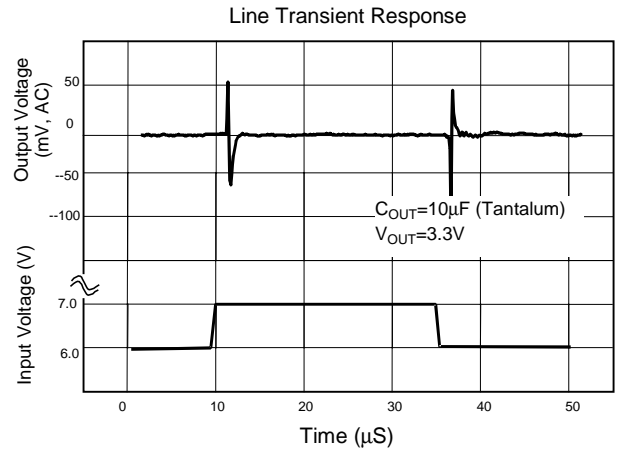
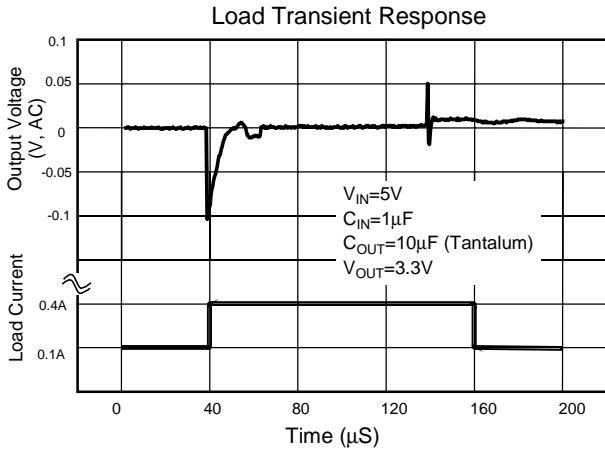

### BLOCK DIAGRAM

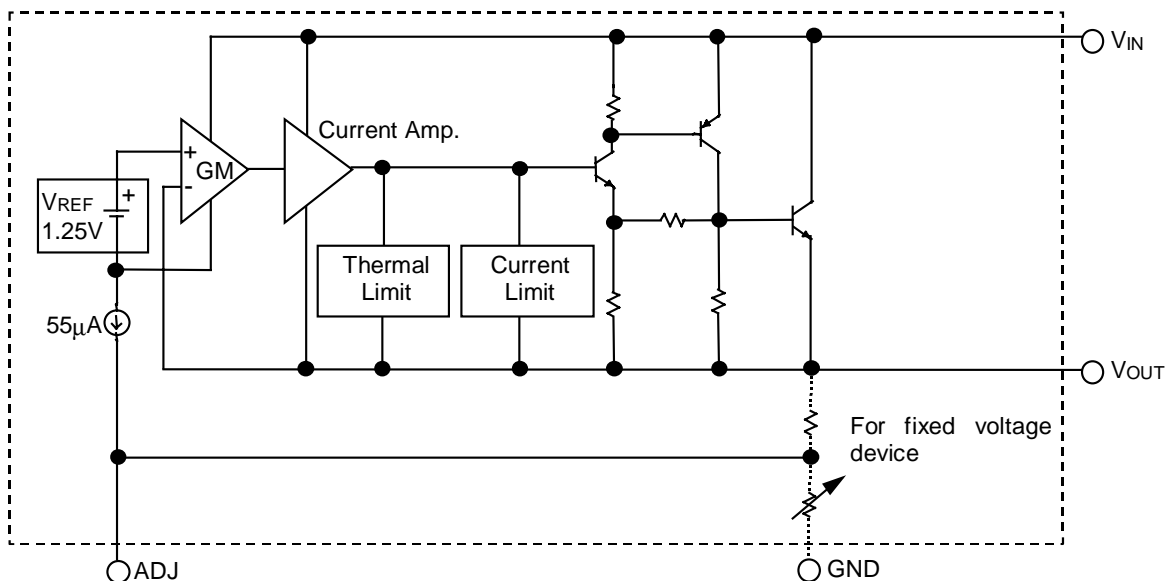



**PIN DESCRIPTIONS**

ADJ PIN - Providing  $V_{REF}=1.25V$  (typ.) for adjustable  $V_{OUT}$ .  $V_{REF}=V_{OUT}-V_{ADJ}$  and  $I_{ADJ}=55\mu A$  (typ.)  
 (GND PIN - Power ground.)

VOUT PIN - Adjustable output voltage.  
 VIN PIN - Power Input.

**PHYSICAL DIMENSIONS**

● TO-220

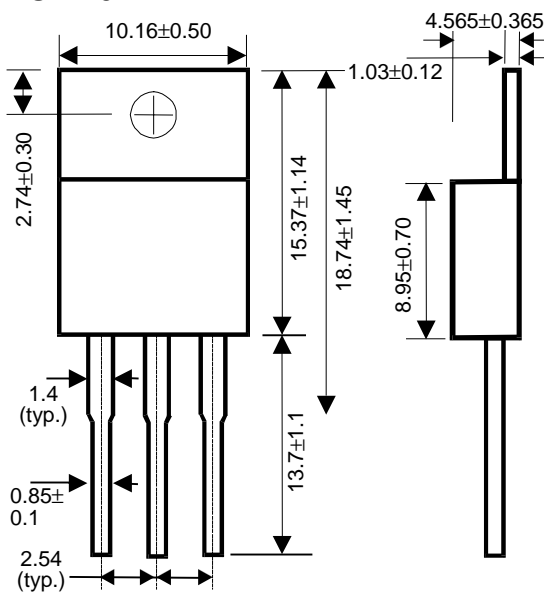

● TO-252

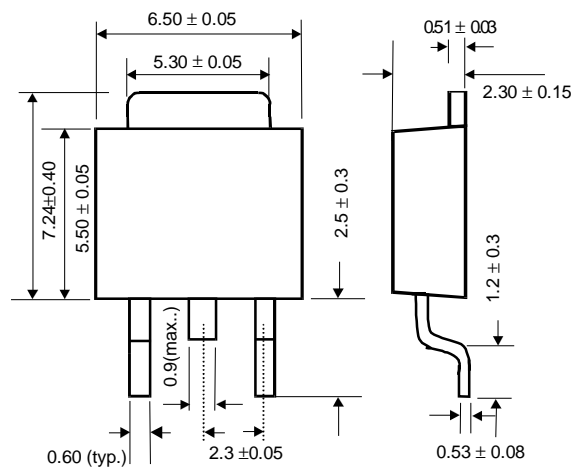

● SOT-223

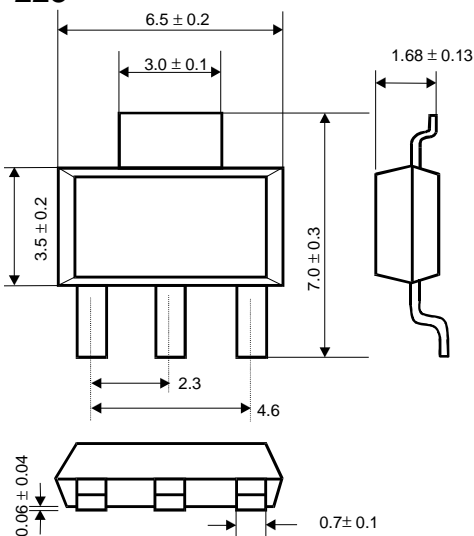

**SOT-223 Marking**

Part No.	Marking
AIC1117CY	AK17
AIC1117-28	AK28
AIC1117-33	AK33
AIC1117-50	AK50

UNIT: mm