



# SST89F5x Oscillator Circuit Design Considerations

Application Note  
August 1999

## 1.0 Introduction

The SST89F5x FlashFlex51 Family of microcontrollers has two modes of clock options: On-chip oscillator and external clock drive. This application note provides oscillator circuit design considerations for the On-Chip oscillator mode.

## 2.0 On-Chip Oscillator

XTAL1 and XTAL2 are the input and output of an inverting amplifier as shown in Figure 1 below. The internal feedback resistor,  $R_f$ , biases the inverter in its linear region and forms a closed loop feedback system. A quartz crystal along with a pair of loading capacitors makes up the external portion of the oscillator circuit. An optional series resistor,  $R_s$ , may be used to limit the overall gain if the crystal is being overdriven.

## 3.0 External Components Selection

Crystal manufacturer, supply voltage, and other factors may cause circuit performance to differ from one application to another. C1 and C2 should be adjusted appropriately for each design. Table 1 suggests some typical values for C1 and C2 at a given frequency. If, following the satisfactory selection of all external components, the circuit is still being overdriven, a series resistor,  $R_s$ , should be added. If there is voltage clipping between  $V_{DD}$  and  $V_{SS}$ , that is usually a good indication that the crystal is being overdriven.

TABLE 1. RECOMMENDED COMPONENTS VALUES

Frequency	C1 and C2	$R_s$ (Optional)
< 8 MHz	90 - 110 pF	100 $\Omega$
8-12 MHz	18 - 22 pF	200 $\Omega$
> 12 MHz	18 - 22 pF	200 $\Omega$

## 4.0 Amplifier Gain

The oscillator circuit consists of an amplifier and a feedback network. In order for oscillation to commence, two conditions must be met: 1) the overall loop gain must be greater than unity. 2) The phase shift must be 0° or 360°. The loading capacitors C1 and C2 must be properly selected to ensure these above conditions are met.

## 5.0 Stability

Stability is achieved once the oscillator is resonant at the desired frequency. Various parameters affect frequency stability but not all are critical. Some parameters a designer should consider are: Temperature, drive level, crystal aging, crystal tolerance and deviation over temperature and frictional wear. Increasing C1 and C2 will improve frequency stability by limiting the drive level, but that also increases startup time. Instead of increasing C1 and C2, use a series resistor,  $R_s$ , to reduce the drive level.

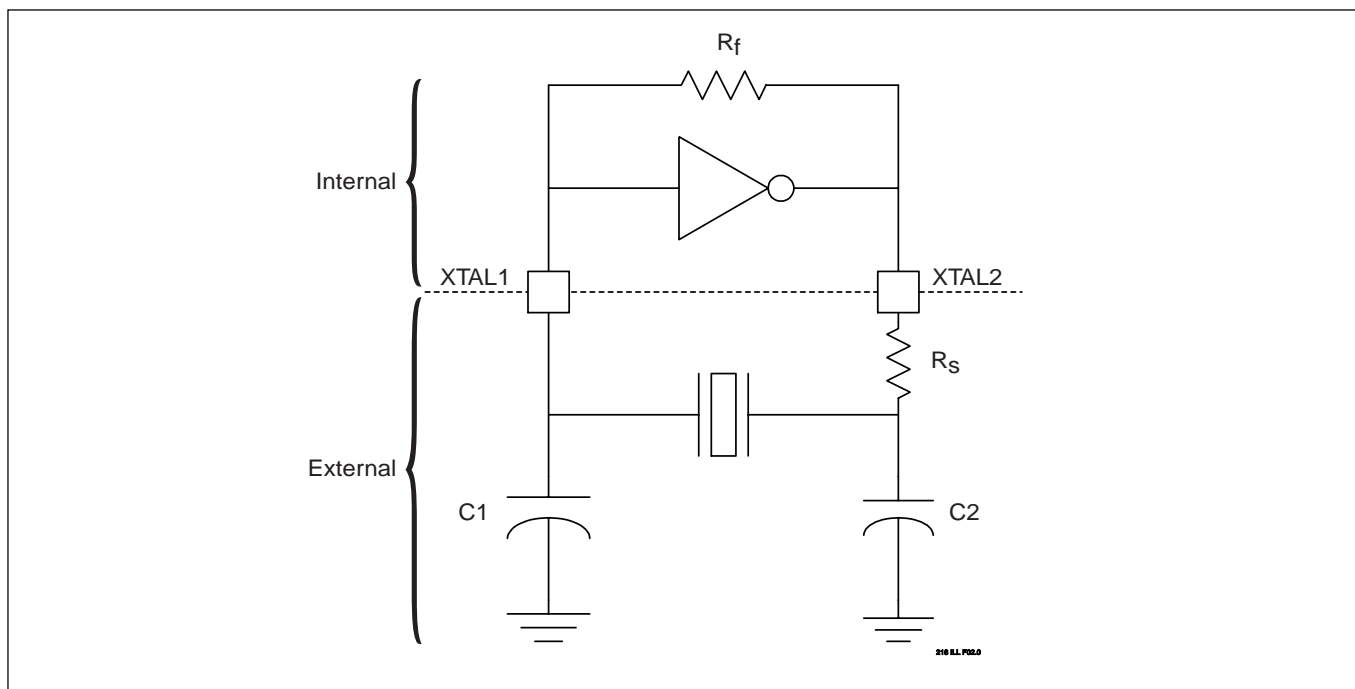

FIGURE 1: ON-CHIP OSCILLATOR

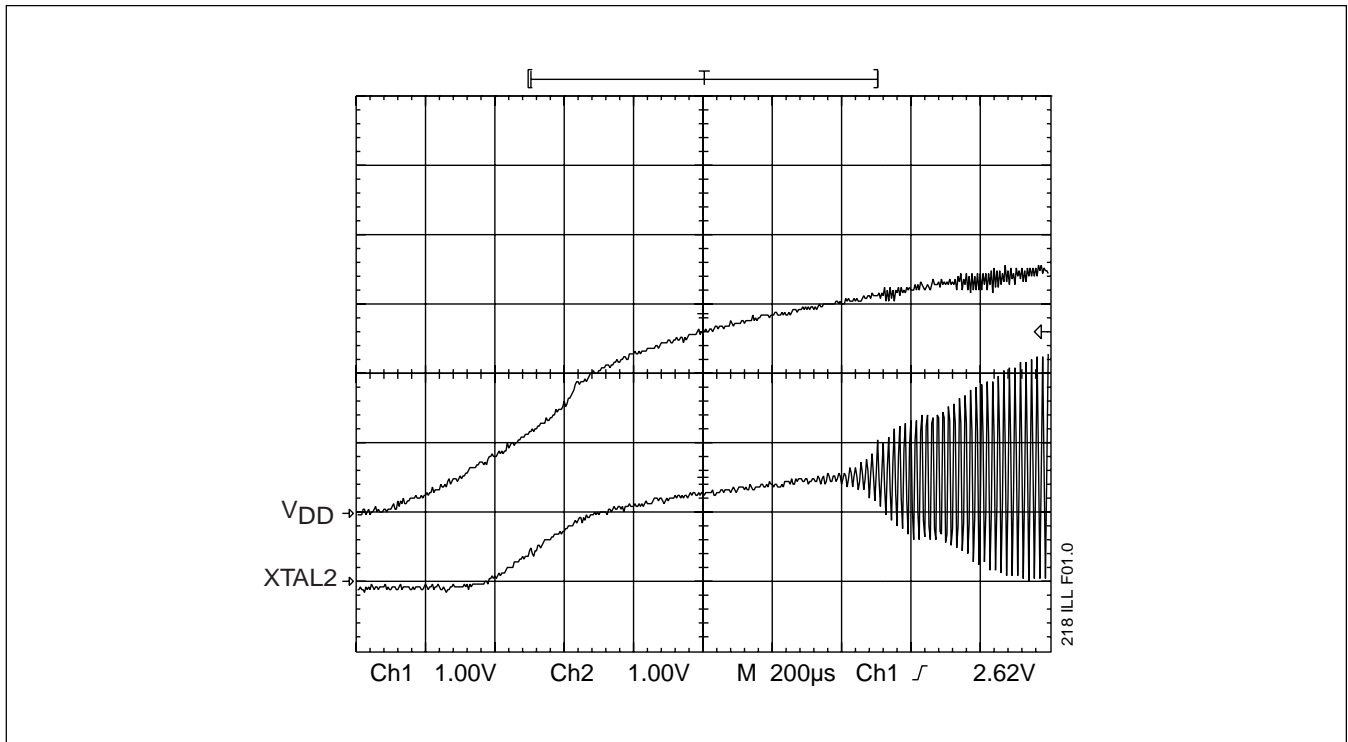

FIGURE 2. OSCILLATOR STARTUP FOR A 11.0592 MHz CRYSTAL

## 6.0 Startup Time

Startup time is critical in an oscillator circuit because of the microcontrollers reset and initialization requirements. Most crystal oscillator circuits typically take between 0.5 to 5ms to startup. Figure 2 shows the startup time for an 11.0592 MHz crystal oscillator circuit. For a low frequency crystal, the startup may take up to several seconds. The latency in startup time can disrupt the Power-on Reset process. To ensure a proper reset, the oscillator must be stable for at least two machine cycles (24 clocks) after achieving stable resonance. Therefore, for a low frequency crystal, it is necessary to extend the reset signal to avoid an invalid reset.

The loading capacitors C1 and C2 should be kept small to minimize startup time but robust enough to provide adequate gain for startup. A higher C2 value can increase the phase shift across the crystal at power-up and help increase the startup time.

## 5.0 Design Considerations

Certain design guidelines must be followed for a good oscillator circuit. Stray capacitances and large inductances must be kept to a minimum to avoid an undesired mode of oscillation and startup issues. A good practice is to keep all trace lengths as short as possible. Components should be isolated in order to prevent signal coupling. Ground planes should be used to isolate signals. Special precautions must be taken for single or double layer board designs with no ground planes. Additionally, a 0.1µF ceramic high frequency, low inductance capacitor connected between V<sub>DD</sub> and Ground should be placed as close to the package terminals as possible to remove power line noise. Refer to the application note on *Design Considerations for the SST FlashFlex51 Family Microcontroller* for general PCB design guidelines.



# SST89F5x Oscillator Circuit Design Considerations

## SALES OFFICES

### SST Area Offices

Customer Service	(408) 523-7754
Northwest USA, Rocky Mtns. & West Canada	(408) 523-7661
Southwest USA	(949) 495-6437
East USA & East Canada	(978) 356-3845
Corporate CEM Accounts	(727) 771-8819
North America - Distribution	(941) 505-8893
Asia Pacific	(408) 523-7762
East Asia	(81) 45-471-1851
Europe	(44) 1932-230555
Northern Europe	(45) 3833-5000

### North American Sales Representatives

<b>Alabama</b> M-Squared, Inc. - Huntsville	(205) 830-0498
<b>Arizona</b> Reptronix, Ltd.	(602) 230-2630
<b>California</b>	
Costar - Northern	(408) 946-9339
Falcon Sales & Technology - San Marcos	(760) 591-0504
Westar Rep Company, Inc. - Calabasas	(818) 880-0594
Westar Rep Company, Inc. - Irvine	(949) 453-7900
<b>Colorado</b> Lange Sales, Inc.	(303) 795-3600
<b>Florida</b>	
M-Squared, Inc. - Clearwater	(727) 669-2408
M-Squared, Inc. - Longwood	(407) 682-6662
<b>Georgia</b> M-Squared, Inc. - Atlanta	(770) 447-6124
<b>Illinois</b>	
Oasis Sales Corporation - Northern	(847) 640-1850
Rush & West Associates - Southern	(314) 965-3322
<b>Indiana</b> Applied Data Management	(317) 257-8949
<b>Iowa</b> Rush & West Associates	(319) 398-9679
<b>Kansas</b> Rush & West Associates	(913) 764-2700
<b>Maryland</b> Nexus Technology Sales	(301) 663-4159
<b>Massachusetts</b> Innovative Applied Solutions	(781) 246-9996
<b>Michigan</b> Applied Data Management	(734) 741-9292
<b>Minnesota</b> Cahill, Schmitz & Cahill	(651) 699-0200
<b>Missouri</b> Rush & West Associates	(314) 965-3322
<b>North Carolina</b>	
M-Squared, Inc. - Charlotte	(704) 522-1150
M-Squared, Inc. - Raleigh	(919) 848-4300
<b>New Mexico</b> Reptronix, Ltd.	(505) 292-1718
<b>New York</b>	
Nova Technology	(516) 661-1800
Reagan/Compar - Endwell	(607) 754-2171
Reagan/Compar - E. Rochester	(716) 218-4370
<b>Ohio</b>	
Applied Data Management - Cincinnati	(513) 579-8108
Applied Data Management - Cleveland	(440) 946-6812
<b>Oregon</b> Thorson Pacific, Inc.	(503) 293-9001
<b>Texas</b>	
Technical Marketing, Inc. - Carrollton	(972) 387-3601
Technical Marketing, Inc. - Houston	(713) 783-4497
Technical Marketing, Inc. - Austin	(512) 343-6976
<b>Utah</b> Lange Sales, Inc.	(801) 487-0843
<b>Washington</b> Thorson Pacific, Inc.	(425) 603-9393
<b>Wisconsin</b> Oasis Sales Corporation	(414) 782-6660
<b>Canada</b>	
Electronics Sales Professionals - Ottawa	(613) 828-6881
Electronics Sales Professionals - Toronto	(905) 856-8448
Electronics Sales Professionals - Montreal	(514) 344-0420
Thorson Pacific, Inc. - B.C.	(604) 294-3999

### International Sales Representatives & Distributors

<b>Australia</b> ACD	(61) 3-762 7644
<b>Austria</b> Endrich Bauelemente Vertriebs GMBH	(43) 2-236236-21
<b>Belgium</b> Memec Benelux	(32) 1540-0080
<b>China/Hong Kong</b>	
Actron Technology Co., Ltd. (HQ) Hong Kong	(852) 2727-3978
Actron Technology Co., Ltd. - Shanghai	(86) 21-6482-8021
Actron Technology Co., Ltd. - Shenzhen	(86) 755-376-2763
Actron Technology Co., Ltd. - Chengdu	(86) 28-553-2896
Actron Technology Co., Ltd. - Beijing	(86) 10-6261-0042
Actron Technology Co., Ltd. - Wuhan	(86) 27-8788-7226
Actron Technology Co., Ltd. - Xian	(86) 29-831-4585
MetaTech Limited (HQ) - Hong Kong	(852) 2421-2379
MetaTech Limited - Beijing	(86) 10-6858-2188
MetaTech Limited - Shanghai	(86) 21-6485-7530
MetaTech Limited - Chengdu	(86) 28-5577-415
MetaTech Limited - Fuzhou	(86) 591-378-1033
MetaTech Limited - Shenzhen	(86) 755-321-9726
<b>Denmark</b> C-88 AS	(45) 7010-4888
<b>Finland</b> Memec Finland Oy	(358)9 350 8880
<b>France</b>	
A2M - Bron	(33) 4 72 37 0414
A2M - Sevres	(33) 1 46 23 7900
<b>Germany</b>	
Endrich Bauelemente	
Vertriebs GMBH - Bramstedt	(49) 4192-8784-0
Endrich Bauelemente	
Vertriebs GMBH - Nagold	(49) 7452-60070
<b>India</b>	
Team Technology - Bangalore	(91) 80-526-1102
Team Technology - Hyderabad	(91) 40-231130
Team Technology - New Delhi	(91) 11-220-5624
<b>Ireland</b> Curragh Technology	(353) 61 316116
<b>Israel</b> Spectec Electronics	(972) 3-6498404
<b>Italy</b> Carlo Gavazzi Cefra SpA	(39) 2-424-1471
<b>Japan</b>	
Asahi Electronics Co., Ltd. - Tokyo	(81) 3-3350-5418
Asahi Electronics Co., Ltd. - Kitakyushu	(81) 93-511-6471
Microtek, Inc. - Osaka	(81) 6-6263-5080
Microtek, Inc. - Tokyo	(81) 3-5300-5515
Ryoden Trading Co., Ltd. - Osaka	(81) 6-6399-3443
Ryoden Trading Co., Ltd. - Tokyo	(81) 3-5396-6218
Silicon Technology Co., Ltd.	(81) 3-3795-6461
<b>Korea</b> Bigshine Korea Co., Ltd.	(82) 2-832-8881
<b>Malaysia</b>	
MetaTech (M) SDN BHD	(60)4-658-4276
Serial System SDN BHD	(60) 4-657-0204
Serial System - Kuala Lumpur	(60) 3-737-1243
<b>Netherlands</b> Memec Benelux	(31) 40-265-9399
<b>Norway</b> Endrich Elektronikk AS	(47) 22 52 13 20
<b>Philippines</b> MetaTech (S) Pte Ltd.	(65) 748-4844
<b>Singapore</b>	
MetaTech (S) Pte Ltd.	(65) 748-4844
Serial System Ltd. (HQ)	(65) 280-0200
<b>South Africa</b> KH Distributors	(27) 11 845-5011
<b>Spain</b> Tekelec Espana S.A.	(34) 91 371-7768
<b>Sweden</b> Memec Scandinavia	(46)8-459-7900
<b>Switzerland</b> Leading Technologies	(41) 27-721-7440/43
<b>Taiwan, R.O.C.</b>	
GCH-Sun Systems Co., Ltd. (GSS)	(886) 2-2555-0880
PCT Limited	(886) 2-2698-0098
<b>United Kingdom</b> Ambar Components, Ltd.	(44) 1296-397396

Revised 8-9-99

Silicon Storage Technology, Inc. • 1171 Sonora Court • Sunnyvale, CA 94086 • Telephone 408-735-9110 • Fax 408-735-9036  
www.SuperFlash.com or www.ssti.com • Literature FaxBack 888-221-1178, International 732-544-2873