

Phase noise to Jitter conversion

1 Introduction

The objective of this paper is the jitter computation based on a phase noise measurement plot.

2 Typical phase noise curve L(f)

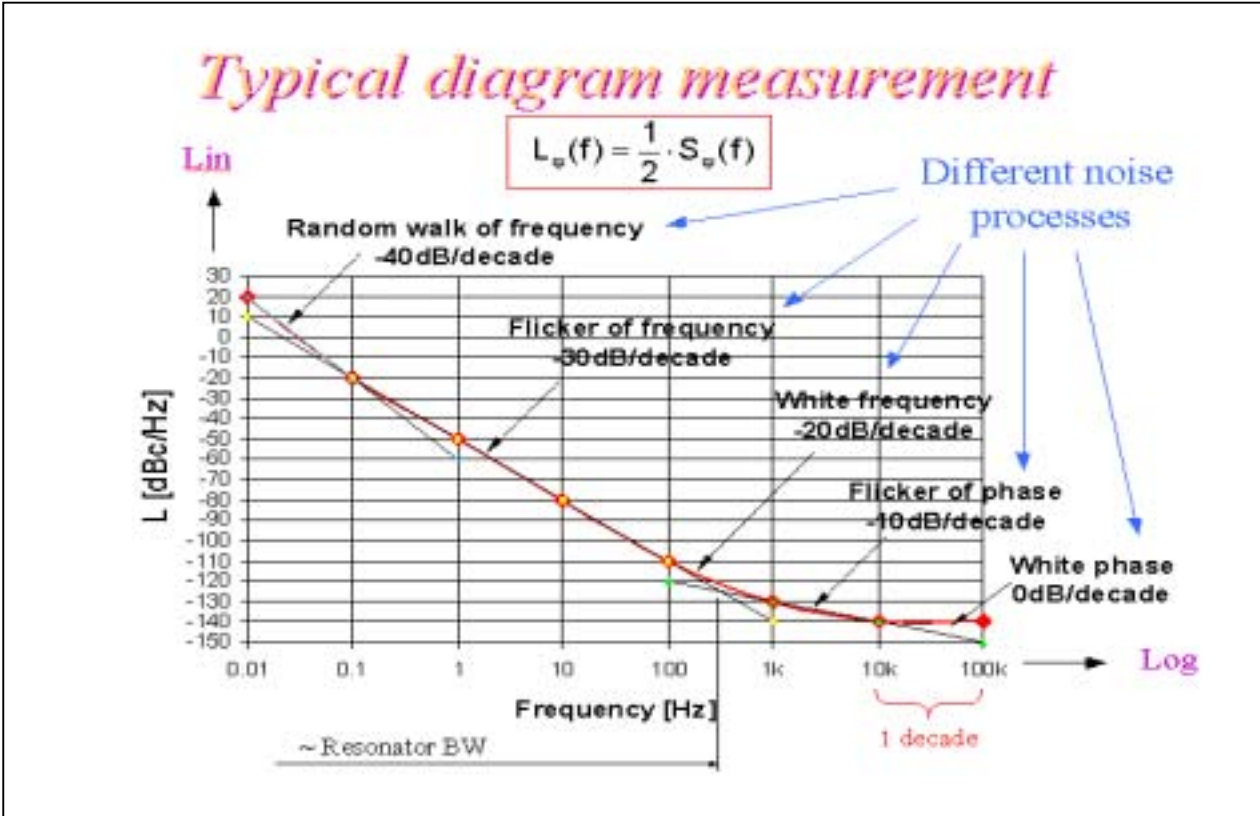

3 Phase noise plot description

Various straight lines can be seen on this graph. This means that noise processes follow a power law :

$$L_{\phi}(f) = \frac{h_{\alpha}}{f^{\alpha}} \quad L(f) \text{ is the sum of each contribution : } L(f) = 10 \cdot \text{Log}_{10} \left[\sum_{\alpha=0}^4 \left(\frac{h_{\alpha}}{f^{\alpha}} \right) \right] \quad (1.1)$$

Each noise process can be expressed in dB and represented on a Log-Lin scale plot :

$$L_{dB}(f) = 10 \cdot \text{Log}_{10} \left(\frac{h_{\alpha}}{f^{\alpha}} \right) = 10 \cdot \text{Log}_{10}(h_{\alpha}) - 10 \cdot \alpha \cdot \text{Log}_{10}(f) \quad (1.2)$$

The L(1 Hz) gives the h_{α} coefficient of each straight line.

$$H_{\alpha} = 10 \cdot \text{Log}_{10}(h_{\alpha}) = L_{dB}(f) + 10 \cdot \alpha \cdot \text{Log}_{10}(f) \quad \text{and} \quad h_{\alpha} = 10^{\frac{H_{\alpha}}{10}} \quad (1.3)$$

4 Jitter-phase noise relationship

A sinewave output signal can be expressed mathematically as follows :

$$V(t) = [A_0 + \varepsilon(t)] \cdot \sin[2 \cdot \pi \cdot f_0 \cdot t + \Delta\phi(t)] \tag{2.1}$$

Where :

- A_0 = nominal peak voltage
- $\varepsilon(t)$ = deviation of amplitude from nominal
- f_0 = nominal fundamental frequency
- $\Delta\phi(t)$ = deviation of phase from nominal

Ideally $\varepsilon(t)$ and $\phi(t)$ should be nil at all time. However, oscillators are not perfect in the real world but, due to saturation processes, $\varepsilon(t)$ is almost negligible and equation (2.1) becomes :

$$V(t) = A_0 \cdot \sin\left[\frac{2 \cdot \pi}{T_0} \cdot \left(t + \frac{\Delta\phi(t)}{2 \cdot \pi \cdot f_0}\right)\right] \quad \text{with} \quad T_0 = \frac{1}{f_0} \tag{2.2}$$

The $\sin(x)$ function equals zero for $x = 2\pi$, therefore (2.2) is cancelled for :

$$t = T_0 + \Delta T = T_0 \cdot \left(1 - \frac{\Delta\phi(t)}{2 \cdot \pi}\right) \tag{2.3}$$

Jitter is expressed as the relative perturbation of the period :

$$J_{UI} = \frac{\Delta T}{T_0} = \frac{\Delta\phi(t)}{2 \cdot \pi} \tag{2.4}$$

Where J_{UI} is the jitter in UI units.

S_ϕ is the spectral density of phase fluctuations and can be intuitively understood as $\frac{\Delta\phi^2}{BW = 1 \cdot Hz}$ so :

$$\Delta\phi^2 = \int_{f_1}^{f_2} S_\phi(f) \cdot df = 2 \cdot \int_{f_1}^{f_2} L_\phi(f) \cdot df \tag{2.5}$$

Finally, jitter is computed using the relation (2.6)

$$J_{UI} = \frac{\sqrt{2 \cdot \int_{f_1}^{f_2} L_\phi(f) \cdot df}}{2 \cdot \pi} \tag{2.6}$$

The main challenge now is to compute the integral based on the phase noise measurement !

5 Summary :

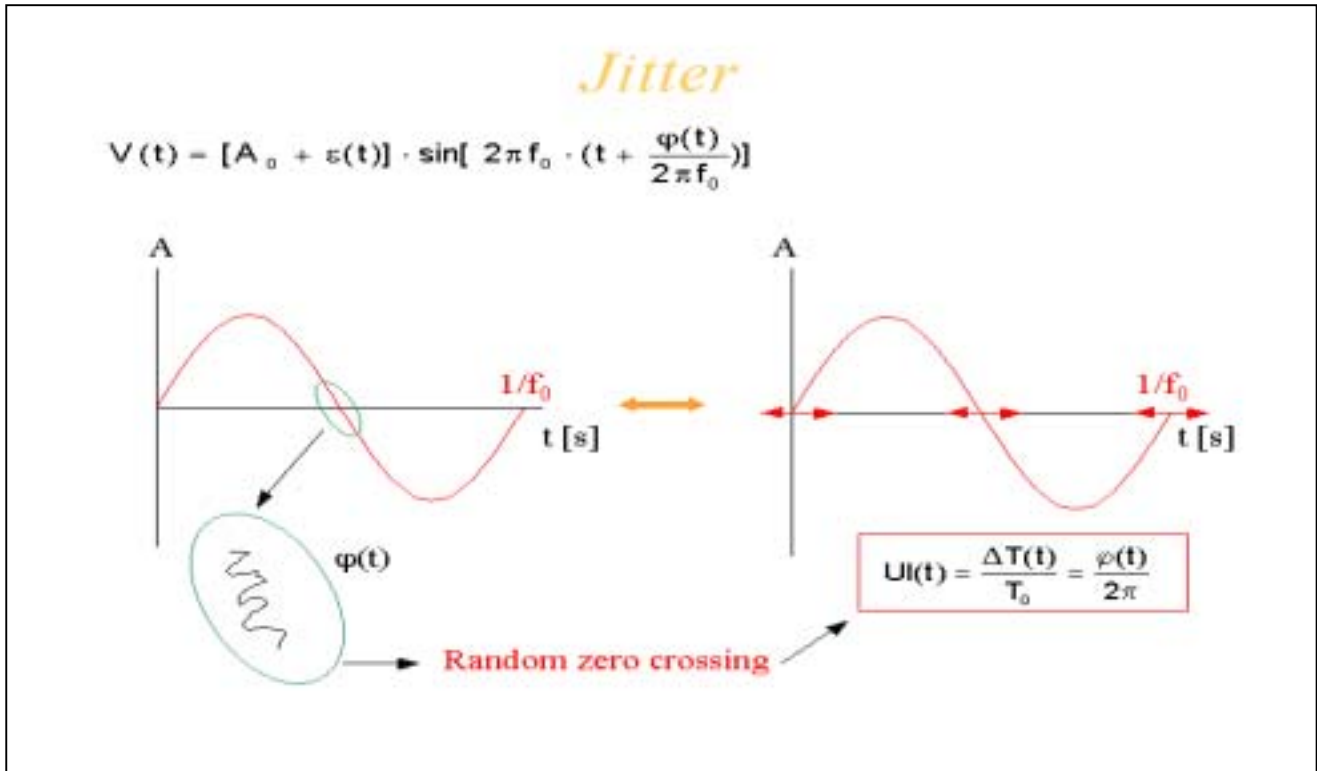

6 Integrated phase noise computation

Basically, two methods can be used to compute the integral of $L_\phi(f)$ depending on the data available :

- “ Graphical “ method
- Numerical method

6.1 “ Graphical “ method procedure :

1. Approximate the graph of $L_\phi(f)$ using straight lines.
2. Compute each h_α coefficient of the power law using equations (1.3)
3. Compute and sum each integral using the following table :

Slope α	$\int_{f_1}^{f_2} \left(\frac{h_\alpha}{f^\alpha}\right) df$
< 0	$h_\alpha \cdot \frac{1}{1-\alpha} \cdot [f_2^{1-\alpha} - f_1^{1-\alpha}]$
0	$h_0 \cdot (f_2 - f_1)$
1	$h_1 \cdot \ln\left(\frac{f_2}{f_1}\right)$
> 1	$h_\alpha \cdot \frac{1}{1-\alpha} \cdot [f_2^{1-\alpha} - f_1^{1-\alpha}]$

4. Compute the jitter in UI rms using equation (2.6)

6.1.1 Example :

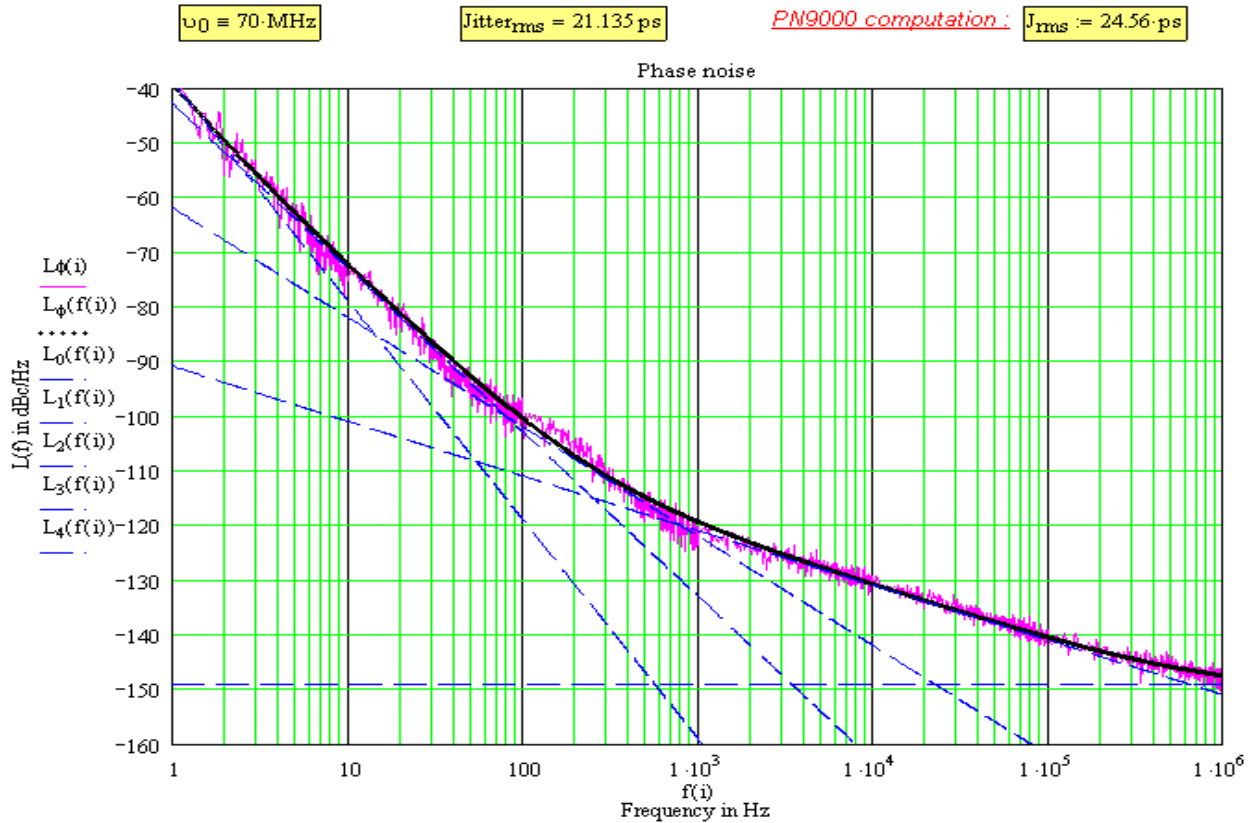

Slope α	f_m [Hz]	L_m [dB]	h_α	f_{\min} [Hz]	f_{\max} [Hz]	\int	Jitter [UI]
4	1	-39	1.259 E-4	1	3	4.041 E-5	
3	10	-73	5.012 E-5	3	80	2.780 E-6	
2	1E3	-122	6.310 E-7	80	800	7.098 E-9	
1	10E3	-131	7.940 E-10	800	660E3	5.334 E-9	
0	1E6	-149	1.259 E-15	660E3	1E6	4.280 E-10	
$\sum(\int) =$						4.320E-5	1.688E-3

With $f_0 = 70\text{MHz}$ we obtain : $J_{\text{rms}} = 21.135 \text{ ps}$

6.1.2 Remarks

1. Result is close to the PN9000 phase noise system computation.
2. Due to straight lines approximation, the result is always smaller than the numerical integration.
3. Straight lines may always be added in order to approximate the phase noise plot more precisely.
4. Phase noise plot generally presents a floor (slope 0) between 100 kHz and 1 MHz. In this case and for SDH/SONET computation (bandwidth = 12 kHz to 5 MHz for instance), extrapolation beyond 1 MHz is possible.

6.2 Numerical method :

The integrated phase noise based on a set of numerical data (L_ϕ, f) is computed. The simplest way is to use the “trapezium method”:

$$\int_{x_1}^{x_2} f(x) \cdot dx = \frac{1}{2} \cdot \Delta x \cdot [f(x_2) + f(x_1)]$$

In our case :

$$\int_{f_1}^{f_2} L_\phi(f) \cdot df = \sum_{i=\min}^{\max-1} \frac{1}{2} \cdot (f_{i+1} - f_i) \cdot [L(f_{i+1}) + L(f_i)]$$

where “min” and “max” correspond to the position of f_1 and f_2 in the data array.

6.2.1 Example :

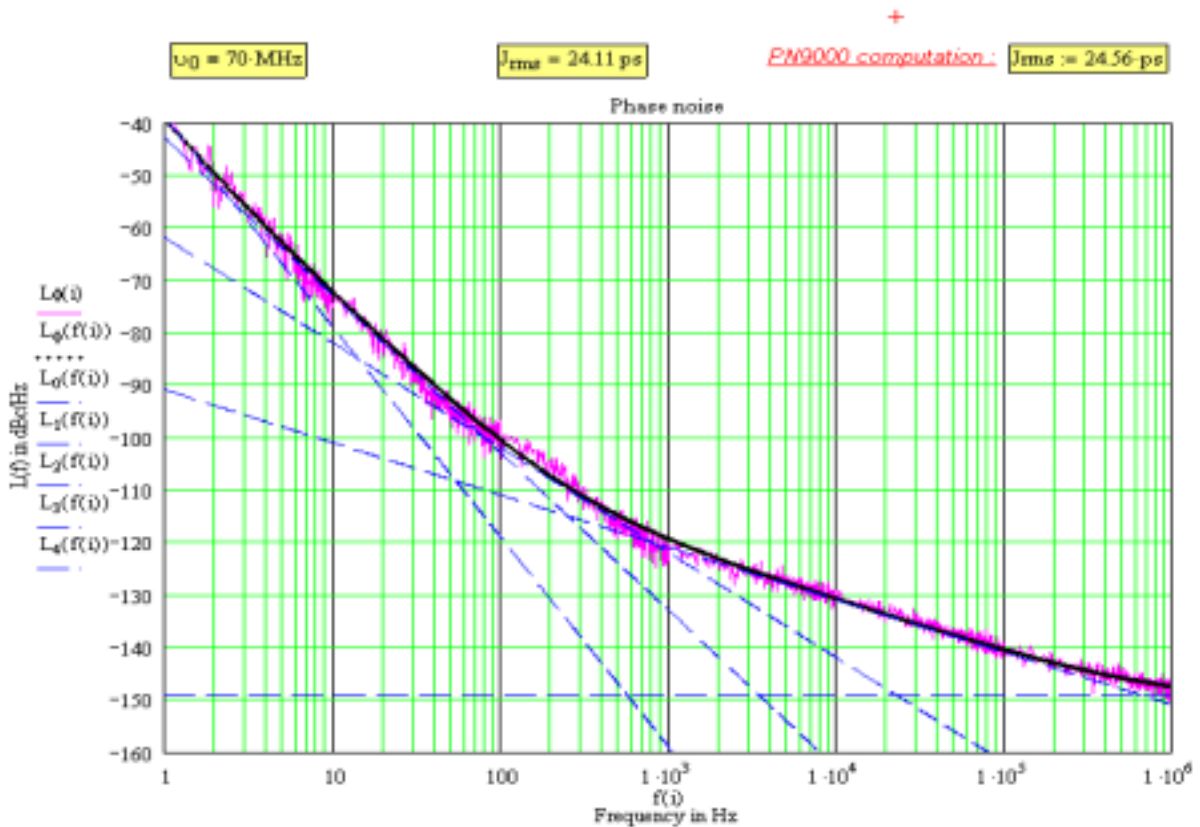

6.2.2 Remarks

In some cases, the plot shows parasitic spectral lines (50Hz etc...). These lines should not be taken into consideration.

7 PN9000 Test system

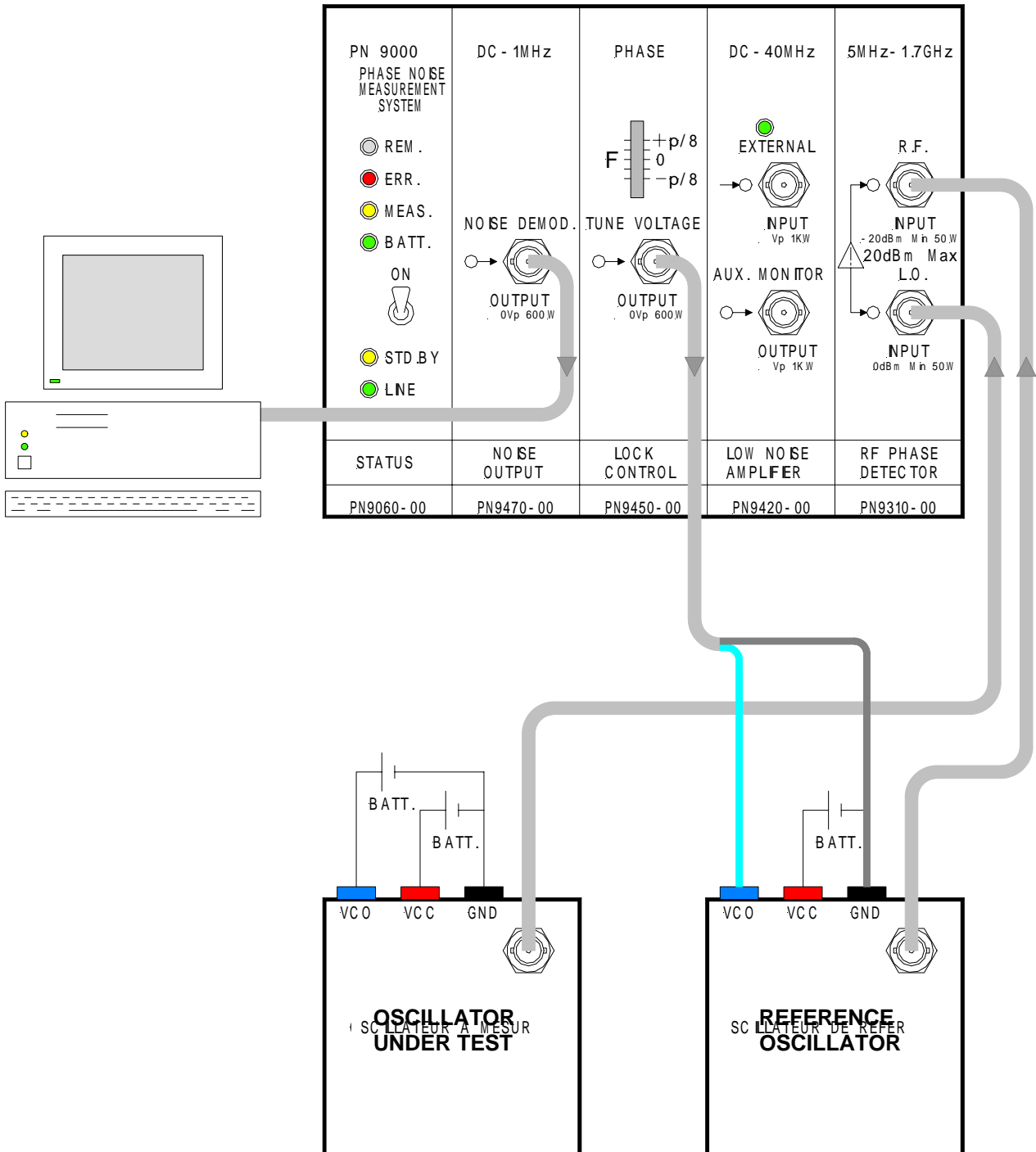

7.1 Block diagram

Measurement system

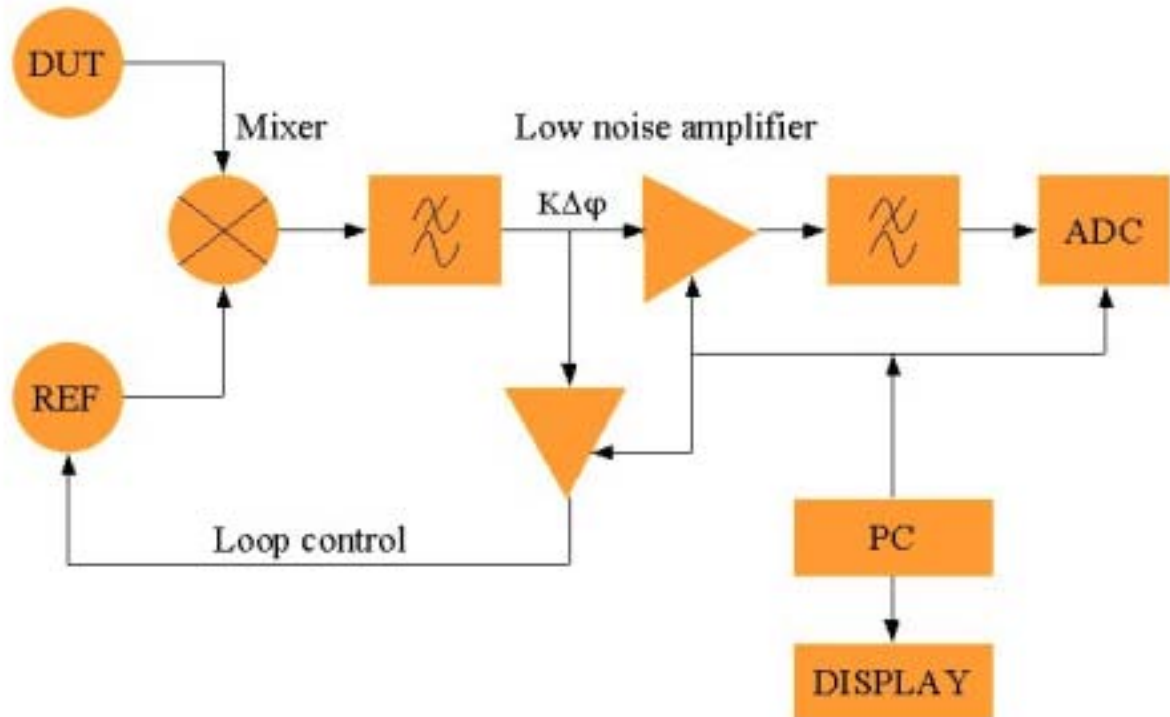

7.2 Note :

This phase noise measurement method is the most sensitive amongst all !